

Features

High-quality hardware

- Functional design
- Logarithmic microphone array layout
- Easy setup and high mobility
- Integration of additional reference channels

Intuitive software

- Turn it on and immediately
 - determine distances to various objects,
 - see sound sources in the video image
 - analyze results retroactively thanks to a circular buffer,
 - evaluate the same recording with different analysis parameters in parallel, and
 - experience all modifications in real time.

In-depth analysis

- Detailed insights into the acoustics of complex measurement objects by analyzing
 - stationary sounds,
 - non-stationary sounds with high time resolution,
 - rotating and RPM-variant measurement objects,
 - large sound-emitting surfaces, and
 - moving objects.

DATA SHEET

HEAD VISOR (Code 7500ff)

System for online localization of sound sources in real time

Overview

HEAD VISOR is a sophisticated beam-forming system for sound identification and analysis.

After turning it on, the entire measurement system is immediately ready for operation. The array determines the distances to all points in the measurement area, allowing sounds to be attributed to the emitting objects with the correct signal levels.

It is not necessary to manually start a recording. Thanks to the permanently active recording buffer (FreezeBuffer), sound events can be easily analyzed even retroactively.

Various additional functions allow for detailed insights into the acoustics of complex measurement objects and adaptations to a wide range of requirements.

In spite of its great capabilities, HEAD VISOR remains an easy-to-use tool. The user always keeps an overview of all important functions and monitors the influences of modifications, filtering, or changes to the sound sources in real time.

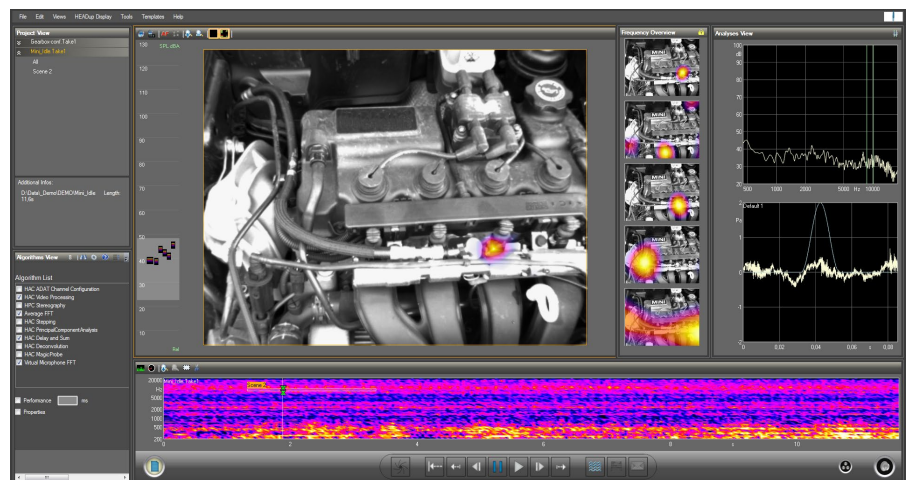

Hardware

Spiral array VMA II.1

The spiral array VMA II.1 is the central hardware element of the HEAD VISOR system. It is easy to transport and can be set up very quickly and connected to the computer via LAN.

The VMA II.1 consists of the spiral array and the front end accommodated by a high-quality case:

- Spiral array
 - 7 spiral arms with 56 microphones, 3 industrial-grade cameras
 - Distance between microphone array and sound source: 0.3 m to 200 m
 - 100 dB dynamic range (microphones)
 - Source mapping standard beamforming
 - Dynamic range: 13 dB
 - Frequency range: 400 Hz to 20 kHz
 - Source mapping advanced algorithms of HEAD acoustics (depending on sound field)
 - Dynamic range: 20 dB to 30 dB
 - Frequency range: 300 Hz to 20 kHz
 - Frequency range near field: 20 Hz to 2000 Hz
 - No recording level adjustment necessary prior to the measurement
- Front end
 - Connection of a HEADlab input module (e.g. *labV6*) for feeding additional sensor information to the data stream
 - Synchronization with a HEADlab system for using several different input modules

Near-field probe HEAD VISOR Probe

Using the HEAD VISOR Probe allows additional low-frequency sound components to be located precisely.

- Ideal for locating sounds with frequencies below 600 Hz
- This allows the entire emitted frequency range from 20 Hz to 20 kHz to be evaluated with a single HEAD VISOR measurement

VMA II.1



VMT I.1 (tripod)

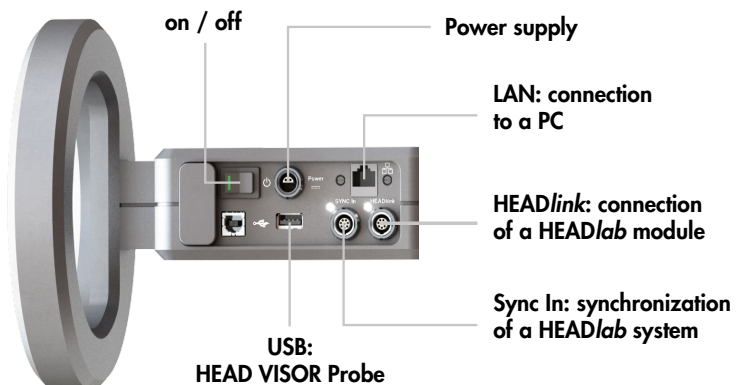

HEAD VISOR Probe

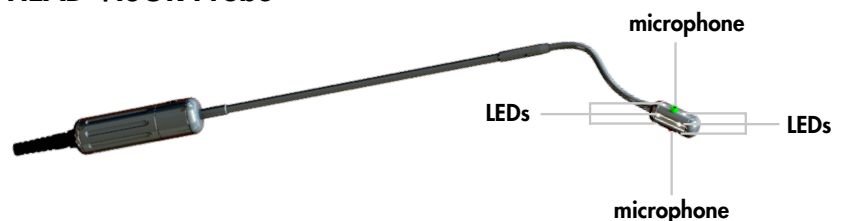

Software

The VISOR software has a modular design. The base version already provides extensive functions for recording, analyzing, and exporting measurements. With individual Tool Packs, special functions can be added.

Basic Software

The basic software provides all essential functions, from data acquisition, measurement data management, and configuration of analysis parameters to the display of the calculated result images in a straightforward interface.

In an FFT vs. Time diagram, the relevant times and the frequencies to be evaluated can be marked.

Two analysis windows allow the time and frequency range of the measurement to be viewed in detail. Frequency and time resolution can be adjusted on the fly, and the results can be viewed immediately in the main analysis window

Real-time principle

All important work steps are performed in real time.

Effects of modifications, filtering, or changes to the sound sources are visible and audible in real time.

FreezeBuffer

The FreezeBuffer function continuously saves e.g. the last 25 seconds in a circular buffer, which can also be accessed retroactively like a saved recording.

Multi-band mapping

The multi-band mapping function allows five additional frequency ranges to be analyzed and displayed in parallel. This allows even wide frequency ranges to be monitored and evaluated completely.

Range meter

The color scale of the source maps can be intuitively adjusted with the range meter in order to achieve the best possible interpretability of the results.

This function displays the plot dynamics as a bar overlaid to a color scale.

This takes place either adaptively in order to highlight the loudest source at any time, or alternatively with an absolute level assignment in order to ensure direct comparability of two measurements.

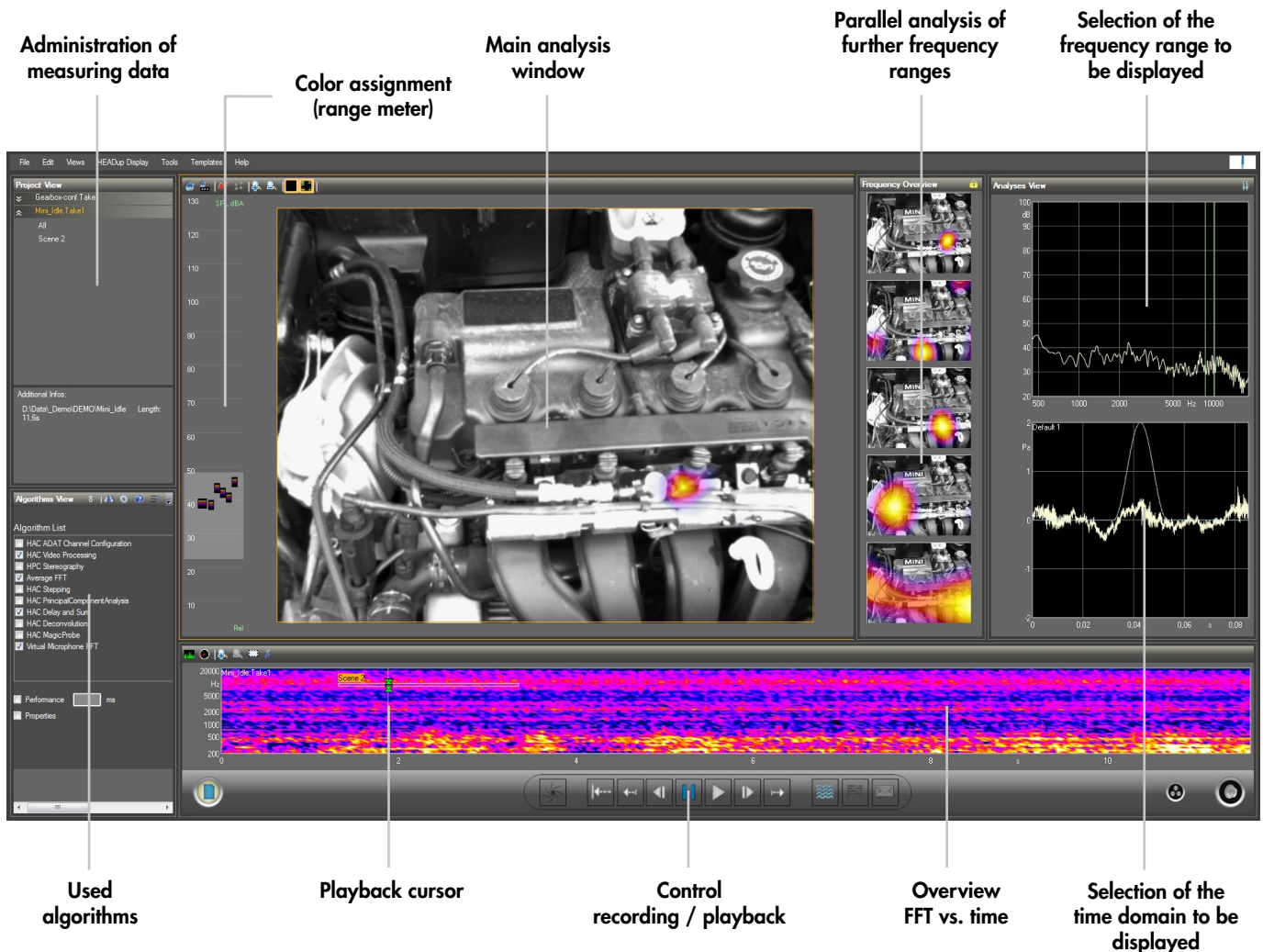

Comparative functions

For a better evaluation or comparison of sound sources, several additional functions are available:

- Synchronized Ranges

For comparison, loaded measurements are displayed with the same color coding as the previous measurement.

- Delta Mapper

Small, relative changes between two setups are highlighted in a difference image (red = louder, blue = quieter).

- HDR function

Detailed results from multiple analyses are combined into a single result image with a high dynamic range.

Playback

Playback and analyses can be performed in slow motion (forward and backward), in a loop, or alternatingly between individual scenes.

Besides the complete sound, it is also possible to filter sound components or orders out of it and play them individually.

In order to play back certain sections of the image only, users can freely place virtual microphones in the image and listen to the sound emitted in that area separately in real time.

Trigger

Triggers are used to start or stop recordings automatically.

Specific frequencies, signal levels, or time events can be used as triggers. It is also possible to use external channels for triggering a measurement.

Export

Measurements and their results can be exported as videos, still images, or as measured and calculated time-domain signals (AVI with sound; PNG, JPG, BMP; WAV, HDF). This allows the results to be further processed in the ArtemiS SUITE, for example.

Screen recorder

The entire user interface can be "filmed" live during an evaluation and embedded into a presentation audiovisually.

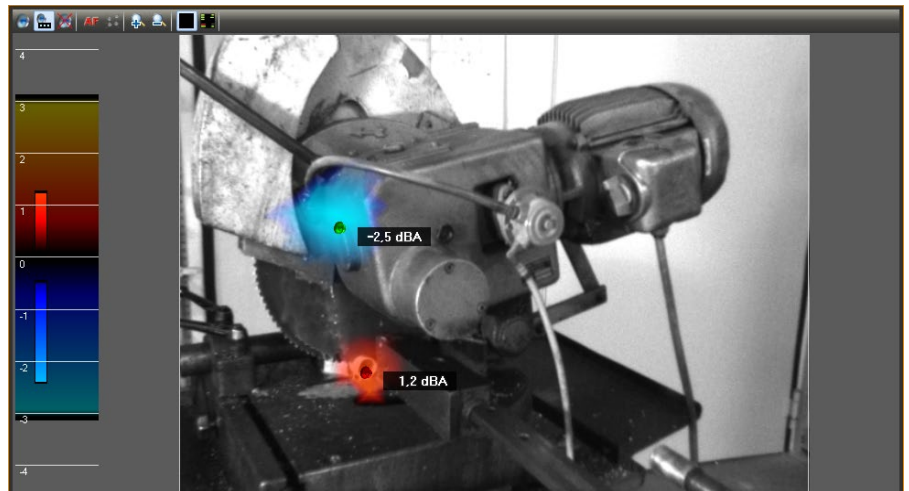

Delta Mapper: Only the differences to the original state are highlighted in color.

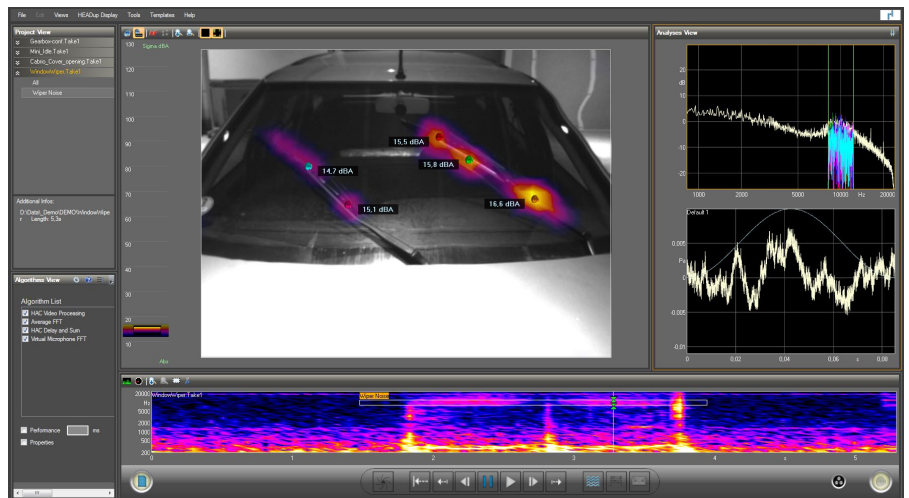

Virtual microphones allow the sound emissions at different positions on the object to be played back.

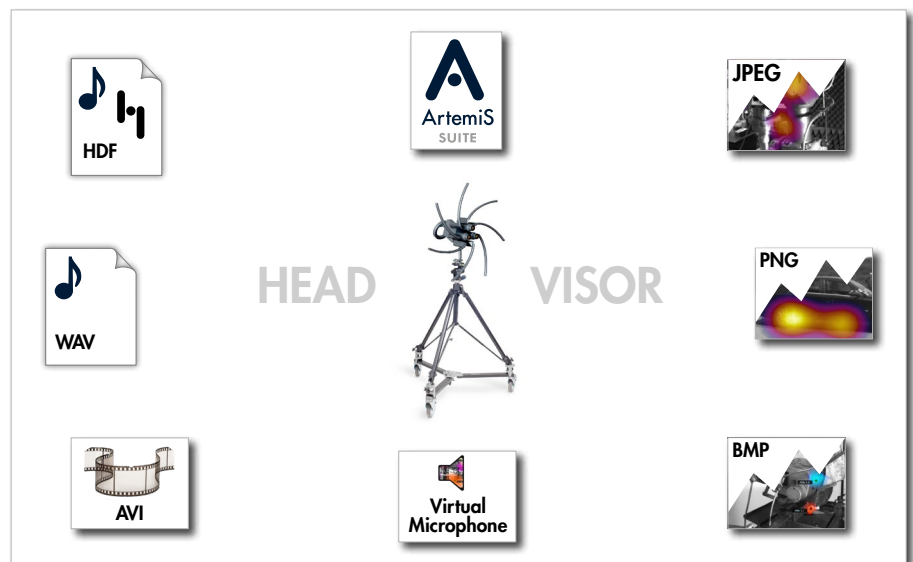

Thanks to extensive export options, the results can be used further in manifold ways.

Software Tool Packs

Tool Pack 01 - MultipleEye focus

- Distance measurement

For high-precision sound source location, the beamforming algorithm requires exact data about the distance between the array and the sound source.

While it would be possible to manually measure the distances to individual objects using a tape measure, at this time it is not yet known where the sound is coming from.

By means of the unique MultipleEye technology, images from the three calibrated cameras can be used to optically acquire the distances to the objects in the field of view. This distance measurement can either be performed in real time or retroactively in offline mode, since all relevant information is recorded. Thanks to this advanced technology, it is possible to focus on different objects in the field of view during the evaluation and to calculate the beamforming always with the exact distance to the object currently in focus.

- Analyzing with the HEAD VISOR Probe

Tool Pack 01 allows low-frequency signals from the near-field probe HEAD VISOR Probe to be included in the analysis. The probe, too, is located via the three cameras.

With the HEAD VISOR Probe, the frequency range to be analyzed can be extended down to 20 Hz.

Tool Pack 02 - Order Analysis Module

- RPM acquisition

Two revolution speeds can be acquired by means of pulse signals and conveniently monitored on tachometers. RPM values can also be used as start and stop triggers.

- Order detection

Orders can be detected by means of revolution speed data and highlighted, e.g. in order to analyze RPM-variant run-ups.

- Pulse Gate

This analysis focuses on a specific time range within a cycle, e.g. in order to analyze the noise emissions of an engine at a certain ignition time point



MultipleEye technology: Three synchronously recording cameras allow the exact distance to any object in view to be determined at any time.

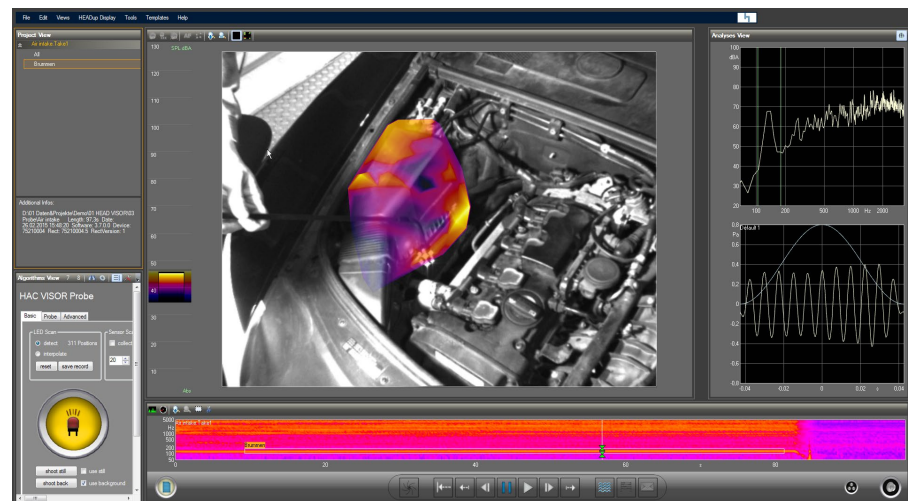

Low-frequency emissions of an air filter at 130 Hz can be recorded using the HEAD VISOR Probe and evaluated in parallel with beamforming.

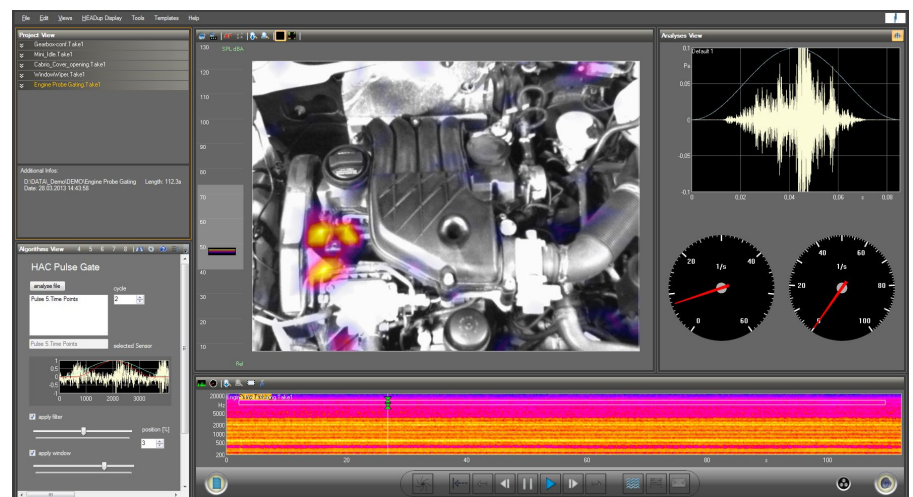

Closely consecutive individual events within one working cycle can conveniently be analyzed at different revolution speeds using a slider (TP 02).

- Derotation

Rotating components can be regarded in a way where the rotation is compensated, e.g. in order to attribute noise signals to the individual blades of an axial fan.

Software Tool Packs

Tool Pack 03 - Advanced Algorithms

Tool Pack 03 provides users with additional algorithms that can be applied before or after the beamforming algorithm. This will enhance the analysis quality of beamforming even beyond the known level.

- Stepping algorithm

With simple mouse clicks, up to eight sound sources can be removed from the measurement, e.g. for an easier analysis of side noise with low signal levels.

- Principal component decomposition

If several sound sources interfere with each other, the measured overall sound can be decomposed into its main emission sources in a first step. Afterwards, these individual sound sources can be separated from the overall sound and located very precisely.

- Coherence filtering and amplification

HEAD VISOR calculates the coherence of the array microphones with a reference signal in real time and filters or amplifies the corresponding components. Reference signals can be delivered by microphones, acceleration sensors, laser vibrometers, etc., but also by a virtual microphone.

Coherence analysis also allows for a differentiation between direct sound and reflections by means of "gated coherence".

Reflections - a common interfering phenomenon in beamforming applications - can thus be identified and removed with a click of the mouse.

- Deconvolution algorithm

If the analysis result appears fuzzy and indistinct, it can be sharpened by means of the deconvolution algorithm. In consideration of the array geometry, this algorithm concentrates the measured diffuse sound fields onto few small main emission sources.

The number of point sources and thus the sharpness of the result can be conveniently adjusted with a slider and viewed in real time (see figure on the right).



Thanks to the stepping algorithm, all sound sources can be detected step by step and combined into an overall image with a high dynamic range thanks to HDR technology.

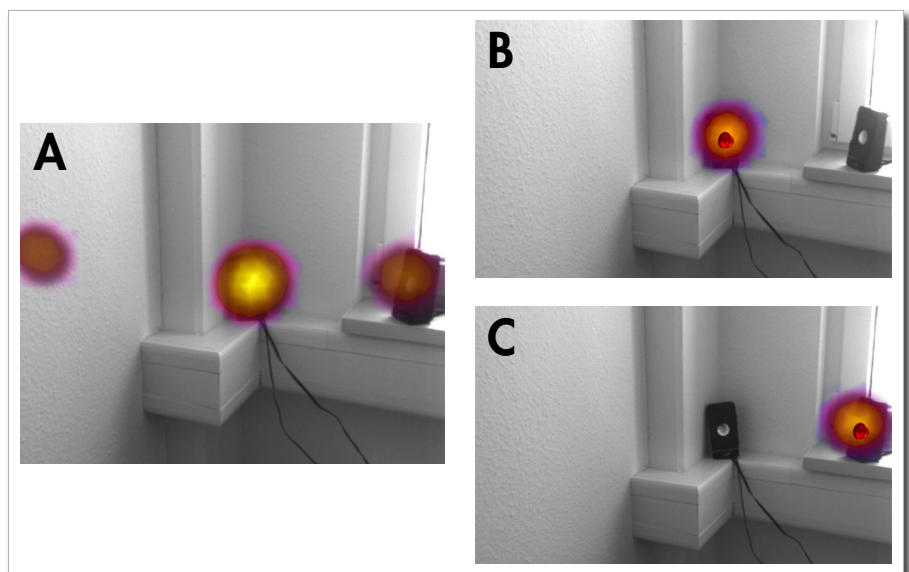

Coherence analysis.

A: Two sound sources, one of them with a wall reflection. B: Only the first sound source is shown. C: Only the second sound source is shown without its reflection.

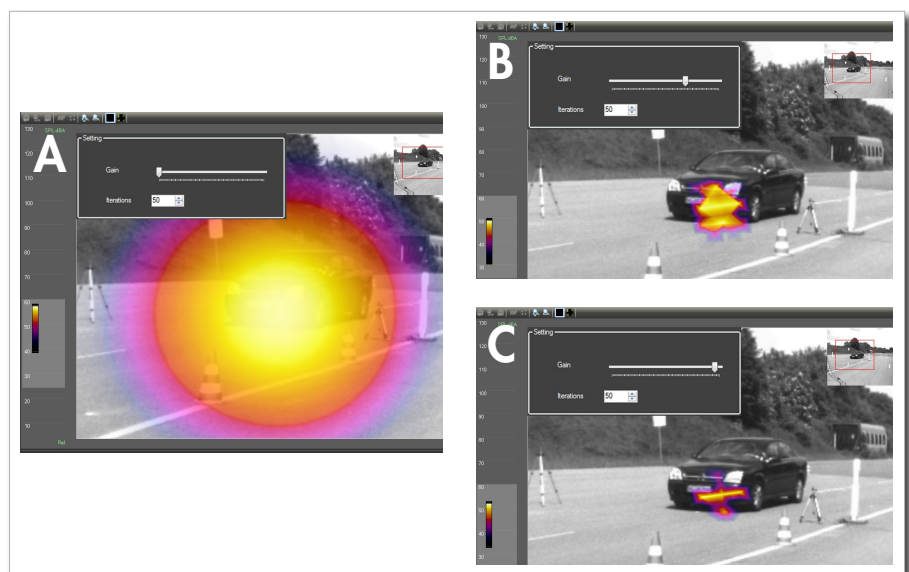



Deconvolution algorithm at a long distance in case of a motor radiation.





A: Only beamforming. B: Beamforming in combination with the deconvolution algorithm. C: Beamforming with a high proportion of the deconvolution algorithm (extraction and ground reflection).

Overview: System components / additional hardware/software

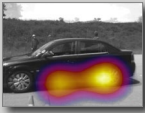

HEAD VISOR hardware components

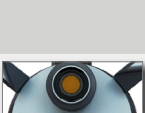
VMA II.1	(Code 7522)		HEAD VISOR Microphone array, spiral version	<ul style="list-style-type: none"> 7 spiral arms, 56 microphones 3 industrial-grade cameras Front end
VMT I.1	(Code 7580)		Tripod with mobile roll car	<ul style="list-style-type: none"> Flexible adjustable up to a maximum height of 2 meters

HEAD VISOR software components

HEAD VISOR	(Code 7500)		Software for real-time identification of sound sources, basic version	<ul style="list-style-type: none"> Beamforming Real-time principle FreezeBuffer Analysis view Synchronized Ranges Delta Mapper HDR function Playback Export
Tool Pack 01	(Code 7501)		MultipleEye focus for distance determination	<ul style="list-style-type: none"> MultipleEye technology Measurements using HEAD VISOR Probe
Tool Pack 02	(Code 7502)		Order analysis module	<ul style="list-style-type: none"> Order detection Pulse Gate Derotation
Tool Pack 03	(Code 7503)		Coherence filtering and enhancement module	<ul style="list-style-type: none"> Coherence filtering and amplification Reflections Stepping algorithm Principal Component Analysis Deconvolution algorithm

Additional hardware

HEAD VISOR Probe	(Code 7523)		Near-field probe for mapping of low-frequency sound sources	<ul style="list-style-type: none"> Examination of stationary near-field sounds, particularly at frequencies below 600 Hz
E.g. labV6	(Code 3721)		Direct connecting a HEADlab input module	<ul style="list-style-type: none"> Connecting up to 6 analog/ICP sensors
HEADlab system	(Code 3700ff)		Using several HEADlab input modules	<ul style="list-style-type: none"> Connecting different sensors: analog/ICP, RPM, pressure/temperature etc.

Additional software

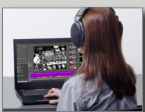
HEAD VISOR core	(Code 7510)		Software for offline analysis (without recorder)	<ul style="list-style-type: none"> All functions of the HEAD VISOR software Without recording function
-----------------	-------------	---	--	--

ICP is a registered trademark of the PCB Group, Inc.