

**APPLICATION  
EXAMPLES  
INCLUDED**



Code 6498

# HRT I

**HEAD acoustics Remote-operated Turntable**

# OVERVIEW

---

## HRT I

**Code 6498**

HEAD acoustics Remote-operated Turntable

HRT I is a high-precision remote-operated turntable developed by HEAD acoustics. It allows orientation-dependent acoustic measurements by rotating the device under test to user-specified angles in the measurement field. Its operation can be fully automated via the HEAD acoustics communication analysis system ACQUA, MATLAB® or Python®. HRT I can also be operated manually via front-side buttons or with the supplied software tool RC-HRT I.

The sturdy design of the turntable ensures its load-bearing capacity of up to 100 kg. The maximum rotation torque of 28 Nm, combined with a reproducibility of 0.02°, allows a highly precise orientation of the measurement object. At idle, the turntable emits virtually no noise to ensure a quiet environment for acoustic measurements.

## KEY FEATURES

---

Rotating unit with high-precision step motor

Unlimited 360° rotation with 0.1° step width

Sturdy mechanical design

LCD display with switchable mode  
(-180° to +180° or 0° to 360°)

No noise emission in measurement position, low noise emission during rotation

Buttons for manual control

Configuration, control and automation via ACQUA, RC-HRT I software tool or scripting

Side-mounted handles for easy transportation

## APPLICATIONS

---

Manual or automated rotation of

- › Telecommunication devices
- › Televisions (with central pedestal)
- › (Video-) conferencing devices
- › Electro-acoustic devices such as
  - » Microphones
  - » Loudspeakers
- › HMS with or without
  - » Torso box HTB VI
  - » Arbitrary accessories (e.g. HHP IV)

# DETAILS

In any type of appliance generating or receiving sound, directivity is an important subject. Testing such devices, e.g. acoustic transducers or microphone arrays, therefore often requires them to be measured at different angles. In a measurement session, manual rotation between each single measurement is error-prone and often cumbersome. A remotely controlled, automatable rotation of the device under test is a convenient alternative. The HEAD Rotating Turntable HRT I was developed by HEAD acoustics for this purpose.

## Construction

HRT I comprises a rotary aluminium plate housed in a sturdy body with height-adjustable feet. The rotary plate is driven by a high-precision stepper motor via a reduction gearbox. The gearbox multiplies the motor's torque while maintaining a maximum angular velocity of 720 degrees per minute with a high angular reproducibility of 0.02 degrees. The maximum rotation torque of the platter is 28 newton meters, its central load bearing capacity is 100 kilograms.

The rotary plate of HRT I has an outer diameter of 43 cm. 24 threaded mounting holes (M6) accept arbitrary custom fittings to hold the DUT in place. In the center of the rotary plate is a removable 90 mm cover to duct cabling through the turntable.

For communication, HRT I uses the industry-standard protocol RS485 via a D-sub 9 connector. Supplied are the ten meter D-sub 9 extension cable CAB II.10 as well as the active D-sub 9-to-USB converter CUD III.

*HRT I with the optional extension plate TEP-100. The extension brings the rotary plate's total diameter to 100 cm. TEP-100 simulates table surface to a device as laid out in many popular standards.*

*As it physically obstructs the emergency stop button of HRT I, TEP-100 is delivered with a secondary external push button.*

## Operation

HRT I can be operated in several ways. Push buttons allow manual control of basic functions such as a reference position reset and rotation in both directions. This can be helpful e.g. to verify unobstructed movement of a device and its cabling.

Connected to a Windows PC, HRT I can be operated with the delivered software RC-HRT I or by the optional HEAD acoustics software ACQUA or VoCAS. Operation can also be automated via RC-HRT I in MATLAB® or Python. ACQUA databases that utilize HRT I already contain control commands for the turntable.

Software operation adds further ways of control such as user-selected angular step increments (in both directions), rotating directly to a user-selected angle (in both directions), setting the rotation speed, the type of acceleration and deceleration and counting the total number of revolutions. Technically HRT I has no physical end points to rotation. However, the majority of appliances placed on the turntable necessitate physical limits, e.g. to prevent overtwisting their cabling. To prevent that, limits can be set as desired for HRT I in software.



When a test case contains many repetitive steps (e.g. clockwise rotation by 10° after each measurement run), the measurement and turntable operation can be combined in an appropriate control program to fully automate the process.

In idle, HRT I is virtually noise-free at 17 dB<sub>SPL</sub>(A). When rotating, noise emission is low (see technical data). In case of an emergency, rotation can be stopped at any time with the push-button on the front panel.

## Options

To simulate a typical table surface to devices, the extension plate TEP-100 is available for HRT I. The plate is mounted on top of the rotary plate and has a total diameter of 100 cm. TEP-100 also has a removable 90 mm center cover as well as 24 threaded M6 holes to fasten devices. To ensure safe operation, TEP-100 is delivered with an additional external emergency stop push-button.

# TECHNICAL DATA

## Mechanics & Statics

Maximum load capacity	100 kg (central load)
Rotary plate diameter	430 mm
Central hole diameter	90 mm (delivered with removable cover plate)
Plate fastening holes	24 × M6
Maximum rotation torque	28 Nm
Unit's moment of tilt	20 Nm

## Operation

Rotation velocity	0 – 2 rpm (configurable via software)
Angle reproducibility	±0.02°
Noise level	
> Idle	Typ. < 17 dB <sub>SPL</sub> (A) at any position
> 100 cm above turntable	Typ. < 33 dB <sub>SPL</sub> (A) with 0.8 RPM, typ. < 41 dB <sub>SPL</sub> (A) with 1.6 RPM
> @ desktop position <sup>1</sup> acc. to ITU-T P.341	
» without extension TEP-100	Typ. < 38 dB <sub>SPL</sub> (A) with 0.8 RPM, typ. < 52 dB <sub>SPL</sub> (A) with 1.6 RPM
» with extension TEP-100	Typ. < 41 dB <sub>SPL</sub> (A) with 0.8 RPM, typ. < 49 dB <sub>SPL</sub> (A) with 1.6 RPM

1. As laid out in Recommendation ITU-T P.341 for group audio terminals.

## Other

<b>Interfaces</b>	
PC connection	D-sub 9 (at HRT I) ↔ USB (at PC), communication standard RS-485
Power supply	LEMO 4-pin, 24 V, 60 W
<b>Dimensions and Weight</b>	
Overall dimensions (Width × Height × Depth)	450 mm × 88 mm × 450 mm (height can be adjusted between 88 mm and 123 mm)
Weight	Approx. 19.0 kg
<b>Environmental Conditions</b>	
Operating temperature range	0°C – 50°C (32°F – 122°F)
Storage temperature range	-20°C – 70°C (-4°F – 158°F)
Humidity	20% – 80% relative humidity (non-condensing environment)

For measurements in which a HMS needs to be rotated, e.g. when testing directional performance of headsets, the optional Stand Base SB HRT (shown on page 6) is available. It is fixed in the center of the rotary plater after removing the center cover. SB HRT can be used with the original platter of HRT I as well as with TEP-100.

## FEATURES

### ROTARY PLATE

The solid aluminium rotary plate has 24 threaded (M6) holes to fasten devices.

### CENTER COVER

The central cover plate can be removed, e.g. to duct cabling through the turntable.

### POWER/RESET

This button doubles as an on/off-switch as well as for setting the plate's current position as the new reference.

### EMERGENCY STOP

The locking push button stops any rotation immediately.



### RECESSED HANDLES

Recessed handles on the left and right side of HRT I allow easy transport of the 19 kg turntable.

### CONNECTORS

A polarity reversal-proof 4-pin LEMO connector for the external power supply. The D-sub socket connects HRT I to a Windows PC for remote operation.

### POSITION DISPLAY

The self-illuminating display shows the current angular position of the turntable in respect to the reference position to one decimal place.

### CONTROL BUTTONS

Two buttons for manual rotation of the turntable. A brief press rotates the table by 0.1°, holding rotates the plate continuously.

# OPTIONAL ACCESSORIES

## Hardware

TEP-100 (Code 6499)

- › HRT I Turntable Expansion Plate  
(100 cm Diameter, incl. Emergency Stop Push-button)

SB HRT (Code 6501)

- › Stand Base for HMS II.x Mounting on HRT I



HRT I with the optional stand base SB HRT (black) for HMS.

The stand base can be fixed on the rotary plate after removing its center cover. SB-HRT can be mounted to the extension plate TEP-100 (see page 3) in the same way. The stand base has an opening below the HMS to duct cabling through the turntable.

## SCOPE OF DELIVERY

HRT I (Code 6498)

- › HEAD acoustics Remote-operated Turntable

RC-HRT I

- › Remote Configuration Software for HRT I

CUD III (Code 6092)

- › Adapter USB ↔ D-sub 9-pin for Control HRT I  
(for connection to ACQUA PC)

CAB II.10 (Code 6093-10)

- › Cable D-sub 9-pin, 10 m  
(RS485 Connection HRT I ↔ ACQUA PC)

Power Supply

- › 24 V DC, 60 W

User Manual

## GENERAL REQUIREMENTS

### Hardware

1 × Windows-PC

- › For Software RC-HRT I

# IN PRACTICE

## APPLICATION EXAMPLES

### Measurement of a Personal Speakerphone with MS Teams

This exemplary test scenario depicts testing a personal speakerphone as laid out in the Microsoft Teams test specification. This test is designed to assess the device's performance in a quiet environment and in the absence of acoustic reflections (an anechoic room).

The speakerphone is placed on HRT I equipped with its extension plate TEP-100, simulating a table with 100 cm diameter for the device. Rotating the DUT is part of the frequency response tests in an anechoic room as well as of the optional tests of stereo calling performance.

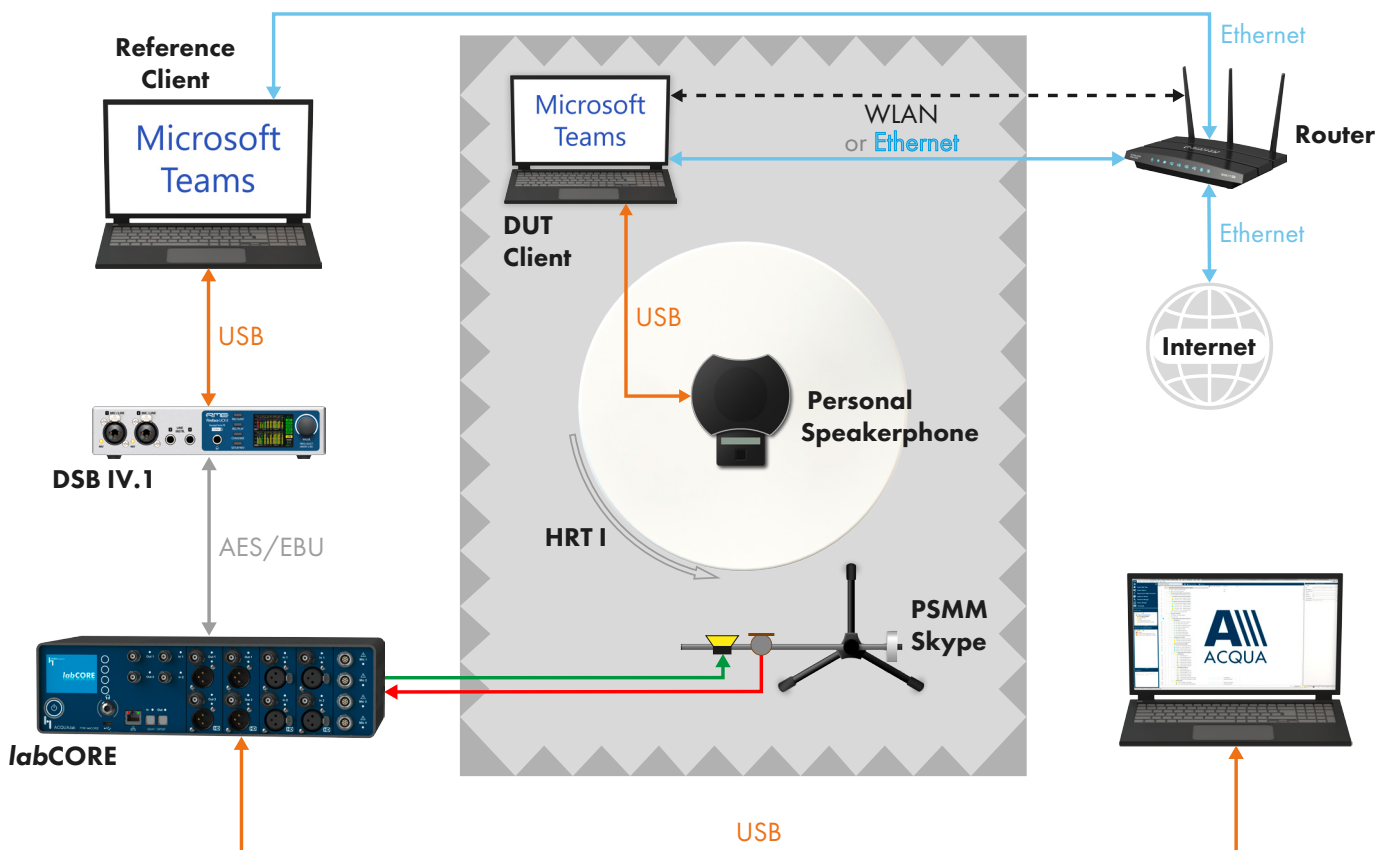

## Measurement of a smart speaker with HQS Smart Home

This exemplary test scenario depicts testing a voice-controlled smart speaker with the HEAD Quality Standard HQS-Smart Home. This test is designed to assess the device's directional behavior. The test suite allows to choose between a

full rotation of HRT I for omnidirectional devices or  $\pm 90$  degrees for directional appliances. The smart speaker is placed on HRT I equipped with its extension plate TEP-100, simulating a table with 100 cm diameter for the device under test.

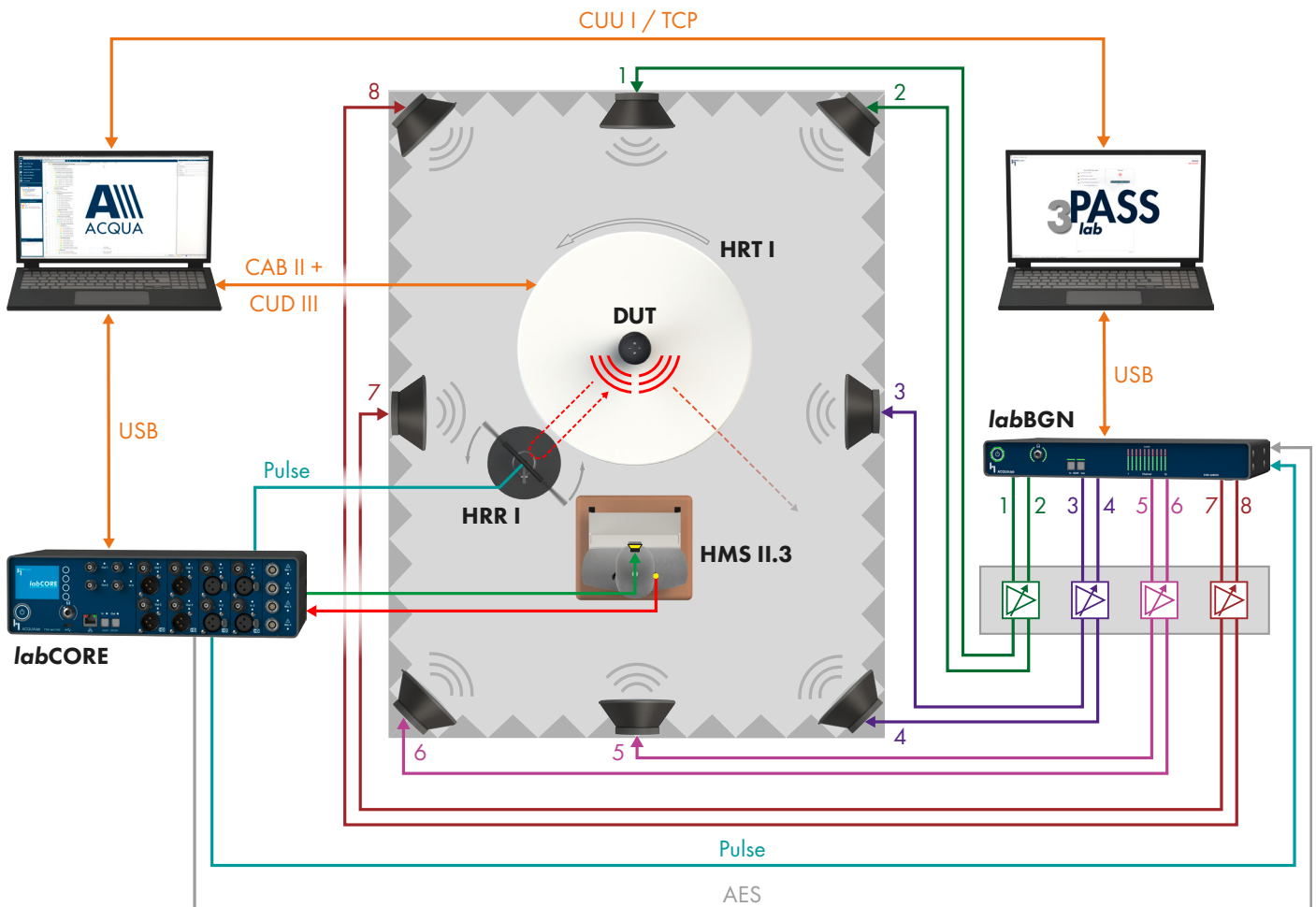

LEMO® is a registered trademark of LEMO S.A.

Microsoft, Windows are trademarks of the Microsoft group of companies.

“Python” and the Python logos are trademarks or registered trademarks of the Python Software Foundation, used by HEAD acoustics GmbH with permission from the Foundation.

MATLAB and Simulink are registered trademarks of The MathWorks, Inc. See [mathworks.com/trademarks](http://mathworks.com/trademarks) for a list of additional trademarks.



### Contact Information

Ebertstraße 30a

52134 Herzogenrath, Germany

**Phone:** +49 (0) 2407 577-0

**E-Mail:** [sales@head-acoustics.com](mailto:sales@head-acoustics.com)

**Website:** [www.head-acoustics.com](http://www.head-acoustics.com)