

# The SenSation.

## SensoGate

Manual and automatic retractable fittings with revolutionary design innovations. Also for applications in hygienic areas.

- High availability
- Low maintenance requirements
- Effective sensor cleaning



# SensoGate Patented Innovation.

SensoGate revolutionizes the principle of conventional push rod fittings. In direct comparison, the maintenance effort is reduced by ten times.



## **Saving Time and Money**

The patented lock-gate principle reliably prevents leakage of process medium during probe movement. Gasket rinsing during the movement and the gimbal bearing of the immersion tube significantly extend the service lives of the gaskets.

## **Advantageous Functionality**

The drive unit of the SensoGate fittings can be detached without special tools. A bayonet coupling also ensures easy and fast maintenance of the immersion tube. In the event of glass breakage, the process-wetted O-ring can be easily replaced. A special prestressed scraper ring prevents formation of ridging on the immersion tube.



### Unique Safety

In every position of the innovative retractable fittings, the process is reliably shut off – even during probe movement.

This also applies without restriction to hygienic applications. In contrast to ball valve fittings, it is not necessary to have any valves before or after the cleaning chamber.

### Versatile Materials

The SensoGate range is also convincing thanks to its extreme material diversity, which is geared toward a wide range of applications. These include high-performance, carbon-fiber-reinforced polymers, which in many cases can replace expensive materials such as titanium or Hastelloy.

### Hygienic Applications

Thanks to the possibility of sterilizing the process side and calibration chamber, SensoGate fittings meet all requirements of food and pharmaceutical production. The special design enables directed flow of the rinse medium; the inner, process-side gasket can be rinsed not only from the process side but also from the interior of the fitting, which normally cannot be reached by the rinse medium. The materials and sealing kits are USP-VI compliant.

### ATEX Approval

SensoGate fittings are approved for operation in hazardous areas in accordance with the II 1 GD c II marking.

# SensoGate

Manual and Automatic Retractable Fittings.

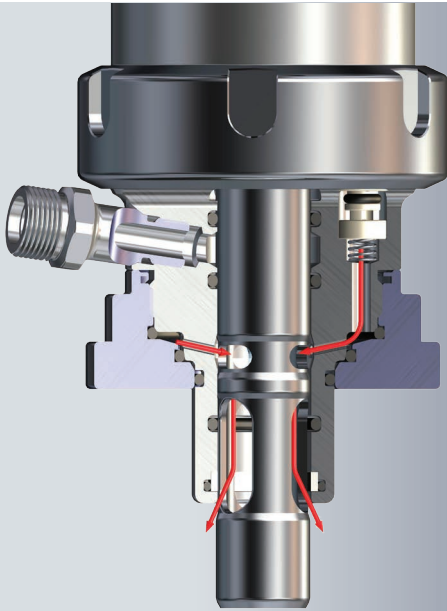

### Gasket Rinsing

SensoGate is the first retractable fitting featuring a sealing water function in combination with a lock-gate. The effective gasket rinsing during the stroke movement – from measurement to the service position and back – reliably prevents the adherence of dirt, fibers and particles. This results in much longer service lives of wear parts with correspondingly reduced maintenance requirements and significant cost savings.

### SensoGate Modular Construction.

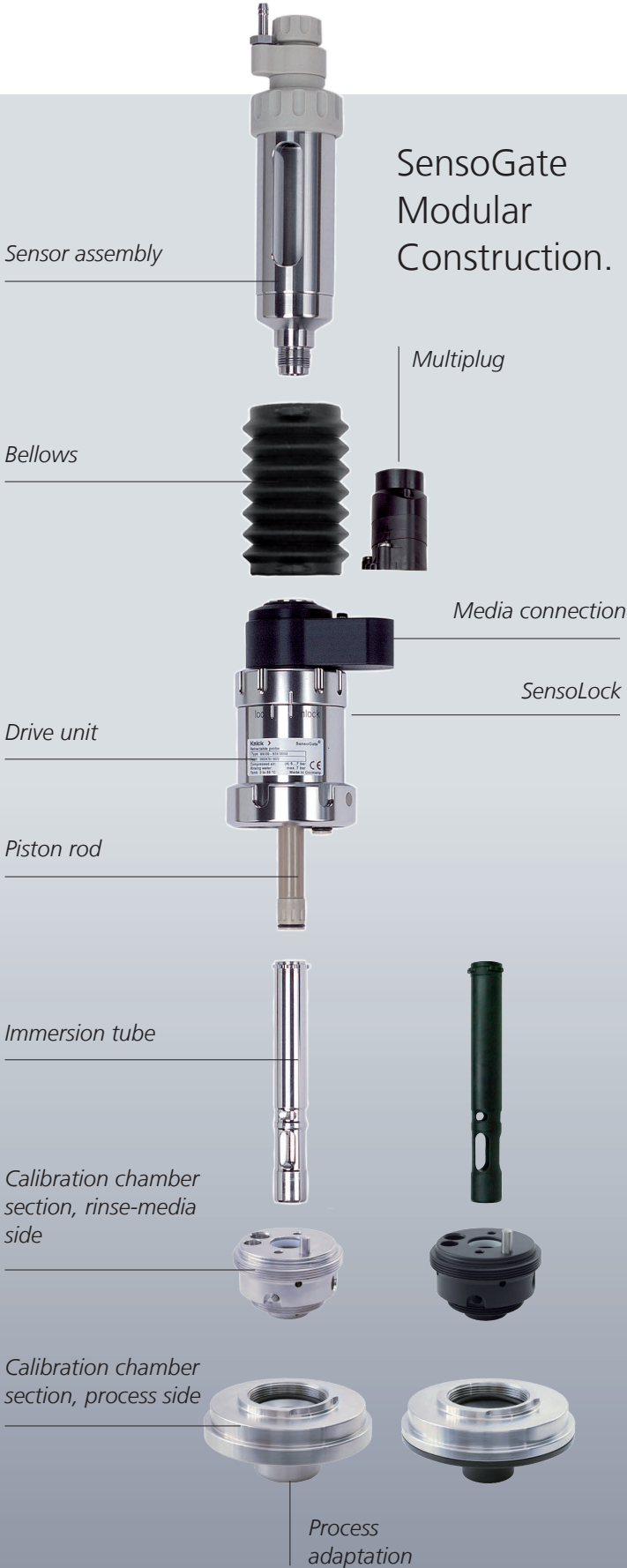





### Systematic Modularity

Thanks to the modular design, individual components can be easily replaced in just a few steps.

The well thought-out design enables reliable, simple and rapid service, even directly on site.

### Quick Replacement

All SensoGate gaskets are easily accessible thanks to the separable calibration chambers. Due to the bayonet coupling, the immersion tube can be quickly replaced.

### Facts and Features

- High availability
- Mechanical pressure and temperature resistance
- Cost minimization through simple installation, operation and maintenance
- Modular design
- Complete replacement of O-rings in just a few minutes
- Patented cyclone rinsing for optimum cleaning effect
- Uniform short sensor length (225 mm) also for long immersion depth
- Special versions for pH sensors with pressurizable liquid electrolyte
- SensoLock feature for high safety of operation
- Universal usability thanks to large selection of materials and a wide range of process connections
- An antitwist lock between the drive unit and the immersion tube ensures defined flow to the sensor in the process.

# SensoGate

One for Everything.

## For process applications

in the chemical industry, for energy generation and in the area of water/ wastewater.



## Large Selection of Process-Wetted Materials

1.4571, 1.4435, Hastelloy C 22, PVDF, PEEK, PP-H, titanium and PTFE. The PVDF, PEEK and PP-H variants are carbon-fiber reinforced. This leads to increased chemical resistance and makes the calibration chamber and immersion tube dimensionally stable even at higher temperatures.

- ATEX approval II 1 GD c II
- Almost all typical process connections

## Unrivalled Chemical Resistance due to PTFE

SensoGate WA 132, WA 133 and WA 133M bring together the advantages of the SensoGate series with the unique chemical resistance of the PTFE material. This is the first time that PTFE retractable fittings will be available with the full variability and modularity of the SensoGate concept.



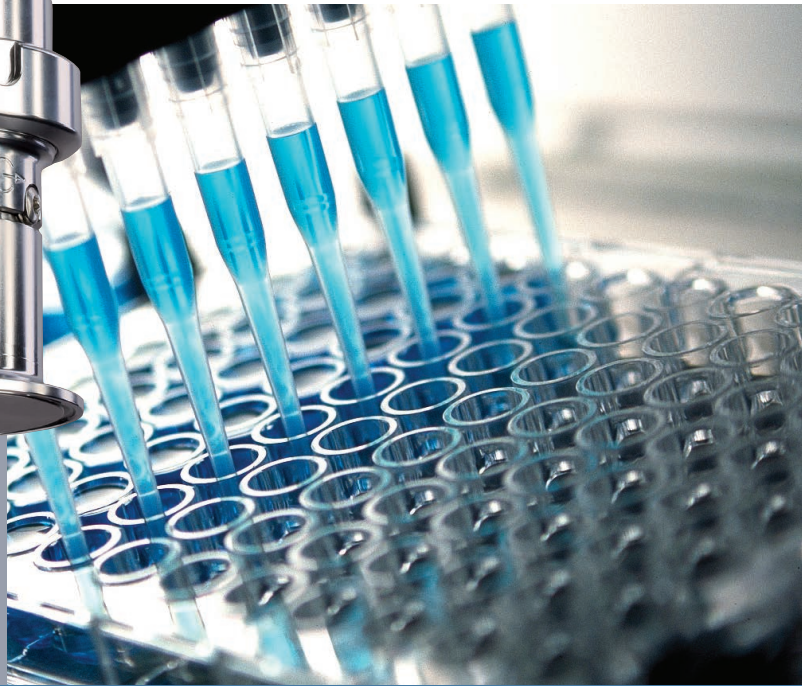

**For hygienic applications**  
in the pharma and food  
industry.



### Technology in Pure Form

The hygienic SensoGate versions are the only fittings on the market that combine hygienic design with a genuine lock-gate feature, with secure separation from the process during stroke movement and prevention of recontamination. Dual gaskets with leakage boreholes reliably prevent microbial contamination of the drive unit.

- SIP and CIP capable
- All standard hygienic process connections

### Process-Wetted Materials

Optionally PVDF (carbon-fiber reinforced), PEEK (carbon-fiber reinforced), stainless steel 1.4404, 1.4435 (electropolished), Hastelloy C 22.



# Fully Automatic Process Analysis

## The System

With the SensoGate retractable fittings in conjunction with the Protos measuring system and electropneumatic control units for cleaning and calibration, Knick has implemented a complete, fully automated measurement loop which provides an extraordinary high level of safety and reliability. Automatic cleaning and calibration is carried out without contamination of the process medium through cleaning or calibration fluids.



Calibrating

Adjusting

Cleaning

Measuring





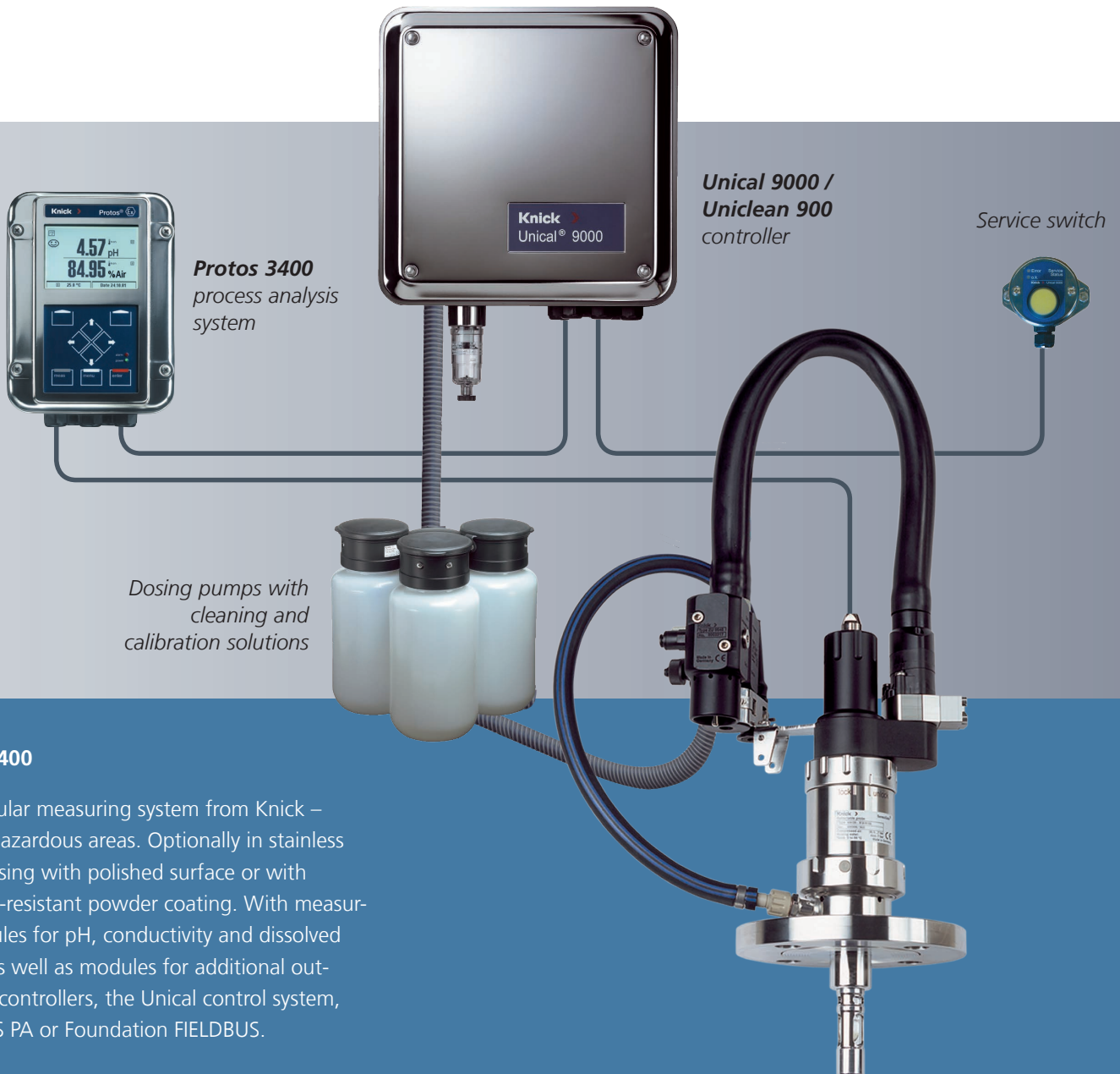

**Protos 3400**  
process analysis system

**Unical 9000 /  
Uniclean 900**  
controller

Service switch

*Dosing pumps with  
cleaning and  
calibration solutions*

**Protos 3400**

The modular measuring system from Knick – also for hazardous areas. Optionally in stainless steel housing with polished surface or with corrosion-resistant powder coating. With measuring modules for pH, conductivity and dissolved oxygen as well as modules for additional outputs, for controllers, the Unical control system, PROFIBUS PA or Foundation FIELDBUS.

**Unical 9000**

Control unit for automatic calibration, cleaning and measuring. Electro-pneumatic controller for minimum maintenance effort with maximum reliability. Automatic calibration without interrupting the production process.

**SensoGate WA 130 /  
WA 130H / WA 132 (PTFE)**  
retractable fitting  
with pH sensor

If the automatic calibration feature is not required:

**Uniclean 900** control unit for automatic cleaning and measuring.

# SensoGate

For Fully Automatic Applications  
with Unical Control System.

## Safe and Convenient

SensoGate for the fully automated measurement loop features easy Plug & Play:

The central multiplug is simultaneously linked via a single connection to all rinsing, cleaning and calibration media as well as the control air and limit position feedback.

The usual tangle of hoses does not exist here.



### Facts and Features:

- ATEX approval II 1 GD c II
- Almost all typical process connections
- High pressure and temperature resistance through carbon-fiber-reinforced plastics, up to 10 bar at 140 °C with PEEK HD



*SensoGate for sensors  
with pressurizable liquid  
electrolyte or polymer  
electrolyte*



### **WA 130**

**Universal, pneumatically operated retractable fitting for fully automatic operation.**

Large selection of process-wetted materials: 1.4571, 1.4435, PVDF, PEEK, PP-H, Hastelloy C 22, titanium

### **WA 132 (PTFE)**

**Pneumatic retractable fitting made of PTFE, with maximum resistance for fully automatic operation.**

- For sensors with pressurizable liquid electrolyte or polymer electrolyte
- PTFE calibration chamber in stainless steel frame, prevents cold flow and wear
- Optimal operation with lined fittings
- FDA compliant

### **WA 130 H**

**Hygienic, pneumatically operated retractable fitting for use with fully automatic Unical controllers.**

- Process-wetted materials, optionally stainless steel 1.4404, 1.4435 (electropolished).
- Additional connection for superheated steam or chemical applications.
  - SIP and CIP capable
  - All standard hygienic process connections



# SensoGate

For Operation with Simple,  
Conventional Controllers.

## Cost-Effective Variability

Based on the proven SensoGate modular design principle, these retractable fittings are ideal for applications which do not require completely automated control but for which superior SensoGate technology is desired.



### Facts and Features:

- ATEX approval II 1 GD c II
- Almost all typical process connections
- High pressure and temperature resistance due to carbon-fiber-reinforced plastics

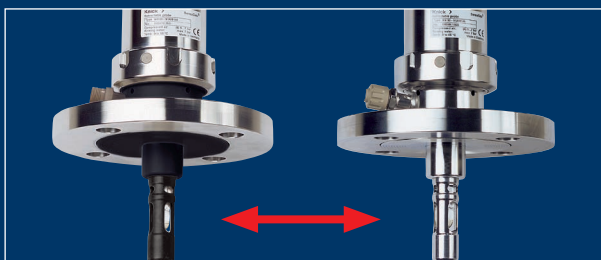

*Easy and quick replacement: stainless steel,  
PVDF, PEEK, PP, Hastelloy, titanium, PTFE*



### WA 131

Universal, pneumatically operated retractable fitting with modular design for simple controllers.

Large selection of process-wetted materials: 1.4571, 1.4435, PVDF, PEEK, PP-H, Hastelloy C 22, titanium

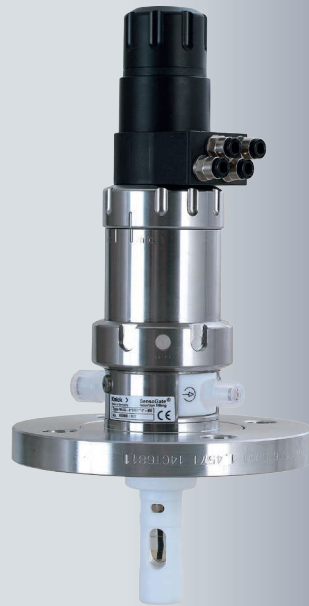

### WA 133 (PTFE)

Pneumatically operated retractable fitting for simple controllers; all process-wetted parts made of PTFE.

- For sensors with pressurizable liquid electrolyte or polymer electrolyte
- PTFE calibration chamber in stainless steel frame, prevents cold flow and wear
- FDA compliant
- Optimal operation with lined fittings



### WA 131 H

Pneumatically operated retractable fitting for simple, commercially available controllers in hygiene applications

- Process-wetted materials, optionally stainless steel 1.4404, 1.4435 (electropolished).
- SIP and CIP capable
  - All standard hygienic process connections

# SensoGate

With Newly Developed  
Manual Rotary Drive.

## Unique Handling

The patented manual rotary drive developed by Knick especially for SensoGate retractable fittings allows the fittings to be operated up to a counter pressure of 10 bar – with just barely under two rotations.



### Facts and Features:

- ATEX approval II 1 GD c II
- Almost all typical process connections
- High pressure and temperature resistance due to carbon-fiber-reinforced plastics







*Unlock  
for rotary drive*

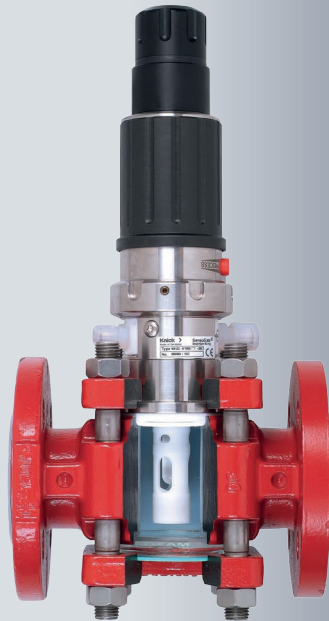

### WA 131 M

Modern manual retractable fitting with unique rotary drive

Large selection of process-wetted materials: 1.4571, 1.4435, PVDF, PEEK, PP-H, Hastelloy C 22, titanium

### WA 133 M (PTFE)

Manual retractable fitting with rotary drive; all process-wetted parts made of PTFE.

- For sensors with pressurizable liquid electrolyte or polymer electrolyte
- PTFE calibration chamber in stainless steel frame, prevents cold flow and wear
- FDA compliant
- Optimal operation with lined fittings

### WA 131 MH

Manual and hygienic; retractable fitting with a new type of rotary drive.

Process-wetted materials, optionally stainless steel 1.4404, 1.4435 (electropolished).

- SIP and CIP capable
- All standard hygienic process connections



**Process Analytics**

- Industrial transmitters
- Fittings
- Automatic cleaning and calibration systems
- Sensors
- Portables
- Laboratory meters

## Knick The Art of Measuring

Knick has been among the leading manufacturers of electronic measurement devices for process analysis for more than 70 years. Today, the company alignment is still focused on a high technical level and an intensely innovative orientation.

The current product range of Knick includes unique device series also for extremely difficult applications. As a system provider, Knick can guarantee expert analysis of your measurement requirements and provide qualified advice for complete measurement loops.

### Authorised distributor

---

**In Australia:**

For customer service, call 1300-735-292  
To email an order, [ordersau@thermofisher.com](mailto:ordersau@thermofisher.com)  
To order online: [thermofisher.com](http://thermofisher.com)

**In New Zealand:**

For customer service, call 0800-933-966  
To email an order, [ordersnz@thermofisher.com](mailto:ordersnz@thermofisher.com)  
To order online: [thermofisher.com](http://thermofisher.com)

**ThermoFisher**  
S C I E N T I F I C