

# Precision Fine Tune™ Control Valve Precisely Controls Landfill Gas Flow



QED's Precision Fine Tune™ Control Valve (U.S. Patent Number 8,800,597) is a revolutionary breakthrough in landfill gas wellfield tuning. Unlike traditional "gate" type valves, this allows you to easily and precisely adjust the gas flow from a well, rather than just turning the flow on or off. The valve design gives you the ability to achieve linear flow adjustment across the entire range of valve movement.

The valve also has a high visibility metered scale that allows you to observe the valve setting, and quickly and accurately return to the exact flow setting after a shutdown. The rising stem valve exposes more of the metered scale as it is opened, allowing you to see and record numerically exactly how far the valve is open.

The valve uses a "flow tuned" design valve plug which allows for fine tuning even at very low gas flow rates (under 10 scfm).



**Heavy duty stainless steel stem and handle outlasts plastic used in standard gate valves**

The rugged stainless steel valve stem and handle make the valve much more durable in the harsh outdoor environment to which landfill gas wells are exposed.

New QED control valve design outperforms common globe and gate valves

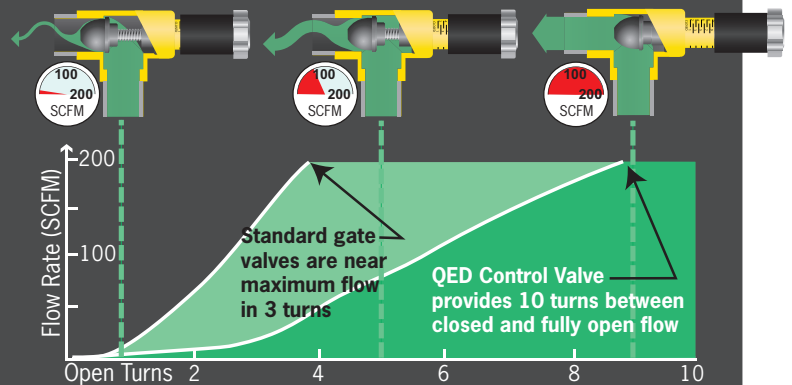

## Fine Tune™ Control Valve Advantages

- Linear flow over the entire range of valve movement, including less than 10 scfm flow.
- Position scale shows exact valve setting and open/closed at a glance.
- Heavy-duty stainless steel stem and handle for strength and long-term durability.

**QED LandFill Gas Products**

P.O. Box 3726 Ann Arbor, MI 48106-3726 USA • (734) 995-2547 • Toll Free (800) 624-2026  
Fax (734) 995-1170 • info@qedenv.com • www.qedenv.com

PRECISION

# QED's Fine Tune™ Control Valve's rugged construction and control outlasts and outperforms standard gate valves

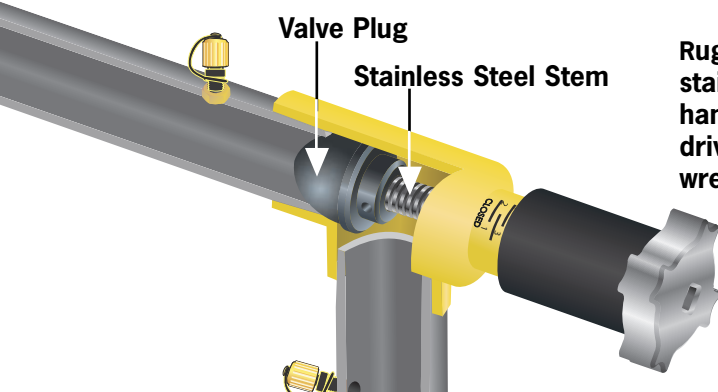

Rugged yet comfortable stainless steel "grip" handle has 1/2" square drive for ratchet wrench if desired

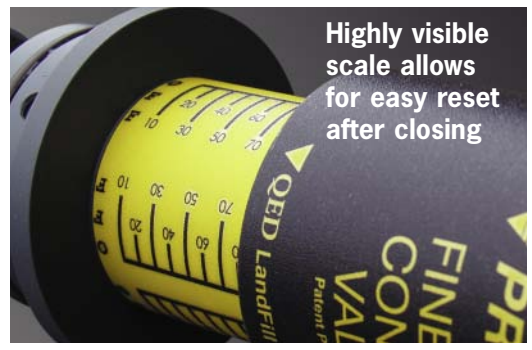

Highly visible scale allows for easy reset after closing



Heavy duty stainless steel stem



**Specifications:**

**Model Number:**

Flow at 40" w.c. vacuum:

Materials:

**2"**

**CV2000**

200 scfm (340 m³/h)

304 Stainless Steel, PVC, Viton

**3"**

**CV3000**

400 scfm (680 m³/h)

304 Stainless Steel, PVC, Viton

**2"**

**ORP215HV**

0-125 scfm (0-212 m³/h)



**CV2000A**

CV2000 with adapter to use the Fine Tune Control Valve with an existing wellhead.

**ORP215HL**

0-125 scfm 9 (0-212 m³/h)



Control Valves not intended for leak tight shutoff over 5 psi

## More Turns = More Fine Tuning Control

As shown in the chart (right), a standard gate valve (blue curve) goes from fully closed to near maximum flow with only 3-4 turns of the handle, making it difficult to set the gas flow with any degree of accuracy.

QED's Precision Fine Tune™ Control Valve (red curve) takes 9+ turns to go from fully closed to near maximum flow, making flow adjustment far more linear. Because QED's valve requires more turns to achieve a given flow rate change, it allows the operator to make more precise adjustments. This is especially true at lower flow rates.

**CV2000 – 2" Valve**

Number of Turns

	0-15 cfm	0-150 cfm
<b>QED</b>	3	8
<b>Other</b>	1	3

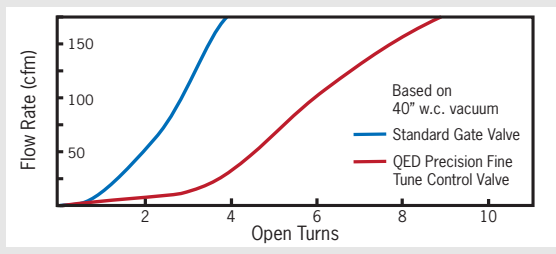

**CV3000 – 3" Valve**

Number of Turns

	0-40 cfm	0-200 cfm	0-350 cfm
<b>QED</b>	3	7	10
<b>Other</b>	1	2	3

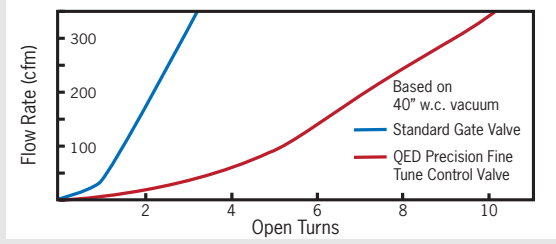

## Authorised distributor

---

### **In Australia:**

For customer service, call 1300-735-292

To email an order, [ordersau@thermofisher.com](mailto:ordersau@thermofisher.com)

To order online: [thermofisher.com](http://thermofisher.com)

### **In New Zealand:**

For customer service, call 0800-933-966

To email an order, [ordersnz@thermofisher.com](mailto:ordersnz@thermofisher.com)

To order online: [thermofisher.com](http://thermofisher.com)

**ThermoFisher**  
S C I E N T I F I C