



PROVEN VIBRATION TEST SYSTEMS

World Class Supplier of Affordable Vibration Test Equipment





About Sentek Dynamics

Sentek Dynamics is focused on turn-key solutions for vibration and environmental testing. With headquarters in Santa Clara, CA and a product demonstration, service and assembly facility in the Charlotte, NC metropolitan area, Sentek Dynamics offers customers coast-to-coast locations for superior service and rapid response. In collaboration with its sister company, Crystal Instruments, Sentek Dynamics develops and markets a wide range of vibration test equipment, environmental test chambers, and instruments for control, data recording, and analysis. Sentek Dynamics offers turn-key vibration and environmental testing solutions for today's demanding test requirements with this comprehensive product line.

Sentek Dynamics has established a team in North Carolina to produce systems that are tested and assembled in the USA from globally sourced parts. The establishment of our local North Carolina facility furthers our commitment to providing high-quality testing solutions.

Sentek Dynamics' products include a wide range of standard and optional features to meet specific test requirements. Vibration testing systems include high-efficiency air-cooled power amplifiers, slip tables in low and high-pressure designs when affordability or high resistance to overturning moments is the

priority, long-stroke options to meet transportation test requirements, air-cooled systems with remote intake and exhaust hose connections for use in labs with controlled environments, simultaneous 3-axis testing systems for reproducing real-world vibration environments in the lab, high-performance shakers with 1470 m/s² (150 g acceleration, motorized gearboxes for shaker rotation, and a variety of isolation systems to avoid the need for a seismic floor. Environmental test systems include chambers with temperature, temperature and humidity, and combined temperature, humidity, and vibration.

The Sentek Dynamics' Team consists of a talented group of engineers, technicians and support personnel with an extensive background in the vibration and environmental testing industry. The design staff includes skilled mechanical and electrical engineers that can rapidly integrate advanced technologies to meet unique customer requirements. This enables Sentek Dynamics to consistently deliver a wide variety of standard and custom engineered products that exceed customer expectations in terms of quality and performance.

Delivery and quality initiatives form an integral part of the Sentek Dynamics culture enabling Sentek Dynamics to consistently deliver a wide variety of standard and custom-engineered products that exceed the specifications of other vibration and environmental test system manufacturers.

Multi-Purpose Test Systems*

* Systems tested & assembled in the USA coming soon. Contact Sentek Dynamics for availability.

Low and Medium-Force Shakers

Sentek Dynamics' L Series and M Series are air-cooled vibration testing systems ideally suited to testing small to medium-sized components and assemblies and are cost-effective solutions to today's demanding test requirements. They are available in vertical only and mono-base configurations (integral slip table). Each system includes the shaker, amplifier, blower, and interconnecting cables and hoses.

- Up to 73.5 kN (16,520 lbf) Sine force capability
- Static payload capability up to 1000 kg (2205 lb)
- Working frequency up to 5000 Hz
- Pneumatic load support
- Air-isolated trunnion

Available options:

- Air-isolation feet, pads or mounts
- Automatic armature centering in static and dynamic modes
- Motorized gearbox for shaker rotation - standard on systems at or above 49 kN (11,010 lbf)

L Series - Low-Force Shakers Air-cooled 0.98 - 9.8 kN (220 - 2200 lbf)

System Performance	L0111A	L0211A	L0315M	L0620M	L1024M
Sine Force Peak kN (lbf)	0.98 (220)	1.96 (440)	2.94 (660)	5.88 (1320)	9.8 (2200)
Random Force rms kN (lbf)	0.98 (220)	1.96 (440)	2.94 (660)	5.88 (1320)	9.8 (2200)
Shock Force (6 ms) kN (lbf)	1.96 (440)	3.92 (880)	5.88 (1320)	11.76 (2640)	19.6 (4400)
Frequency Range Hz	5-4500	5-4500	5-4500	5-5000	5-3100
Continuous Displacement mm (in)	25 (1.0)	25 (1.0)	40 (1.6)	51 (2.0)	51 (2.0)
Max Velocity m/s (in/s)	2 (78.7)	2 (78.7)	2 (78.7)	2 (78.7)	2 (78.7)
Max Acceleration Sine Peak m/s ² (g)	490 (50)	980 (100)	980 (100)	980 (100)	980 (100)
Armature Diameter mm (in)	110 (4.3)	110 (4.3)	150 (5.9)	200 (7.9)	240 (9.5)
Effective Armature Mass kg (lb)	2 (4.4)	2 (4.4)	3 (6.6)	6 (13.2)	10 (22.0)
Max Static Payload kg (lb)	70 (150)	70 (150)	120 (260)	200 (440)	200 (440)

New High-force, Air-cooled 73.5 kN (16,520 lbf) Vibration Testing System

Sentek Dynamics' new M7544A air-cooled vibration testing system offers a high-force test capability with reliable, low-maintenance air-cooling. It is ideally suited to testing large aerospace, automotive and military components. Numerous options are available, including automatic armature centering in static and dynamic modes and a 76 mm (3 inch long-stroke) option to meet today's low-frequency, long-stroke transportation testing needs.

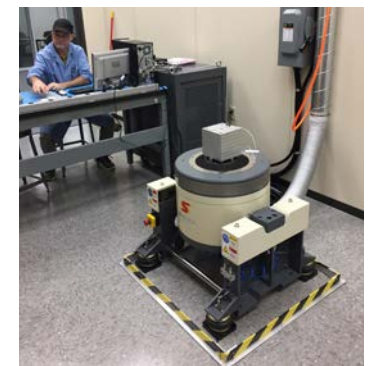
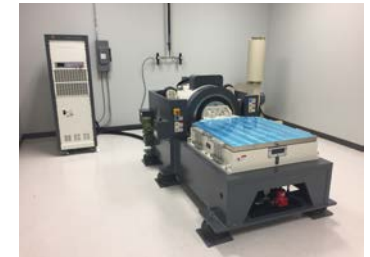

M Series - Medium-Force Shakers Air-cooled 14.7 - 73.5 kN (3300 - 16,520 lbf)

System Performance	M1528A	M2232A	M3240A*	M4040A	M5044A*	M5064M	M6044A	M6544A	M7544A
Sine Force Peak kN (lbf)	14.7 (3300)	21.56 (4840)	31.36 (7050)	39.2 (8810)	49 (11,010)	49.0 (11,010)	58.8 (13,210)	63.7 (14,320)	73.5 (16,520)
Random Force rms kN (lbf)	14.7 (3300)	21.56 (4840)	31.36 (7050)	39.2 (8810)	49 (11,010)	49.0 (11,010)	58.8 (13,210)	63.7 (14,320)	73.5 (16,520)
Shock Force (6 ms) kN (lbf)	29.4 (6600)	43.12 (9680)	62.72 (14,100)	78.4 (17,620)	98 (22,020)	98 (22,020)	117.6 (26,420)	127.4 (28,640)	147 (33,040)
Frequency Range Hz	5-3000	5-3000	5-2500	5-2200	5-2500	2-2300	5-2500	5-2500	5-2400
Continuous Displacement mm (in)	51 (2.0)	51 (2.0)	51 (2.0)	51 (2.0)	51 (2.0)	51 (2.0)	51 (2.0)	51 (2.0)	51 (2.0)
Max Velocity m/s (in/s)	2 (78.7)	2 (78.7)	2 (78.7)	2 (78.7)	2 (78.7)	1.8 (70.9)	2 (78.7)	2 (78.7)	2 (78.7)
Max Acceleration Sine Peak m/s ² (g)	784 (80)	980 (100)	980 (100)	980 (100)	980 (100)	784 (80)	980 (100)	980 (100)	980 (100)
Armature Diameter mm (in)	280 (11.0)	320 (12.6)	400 (15.7)	400 (15.7)	445 (17.5)	640 (25.2)	445 (17.5)	445 (17.5)	445 (17.5)
Effective Armature Mass kg (lb)	18 (39.7)	22 (48.5)	32 (70.5)	40 (88.2)	49 (108)	63 (139)	49 (108)	60 (132)	65 (143)
Max Static Payload kg (lb)	300 (660)	300 (660)	500 (1100)	500 (1100)	1000 (2200)	1000 (2200)	1000 (2200)	1000 (2200)	1000 (2200)

*Available with larger 640 mm (25.2 inch) diameter armature for additional mounting space

Real World Dynamic Simulation Systems*

* Systems tested & assembled in the USA coming soon. Contact Sentek Dynamics for availability.

Long-Stroke Shakers

Transportation and package test requirements require low-frequency and large displacement performance. Sentek Dynamics' long-stroke T Series vibration testing systems are designed for test requirements typically performed by servo-hydraulic shakers. Compared to a servo-hydraulic shaker where the maximum test frequency is limited to approximately 450 Hz, Sentek Dynamics' T Series is capable of up to 3000 Hz.

- Up to 52.9 kN (11,890 lbf) Sine force capability
- Static payload capability up to 800 kg (1760 lb)
- Working frequency up to 3000 Hz
- Displacements up to 100 mm (3.9 in)
- Pneumatic load support
- Air-isolated trunnion

Available options:

- Air-isolation feet, pads, or mounts
- Automatic armature centering in static and dynamic modes
- Low and high-pressure slip tables for horizontal testing
- Motorized gearbox for shaker rotation

T Series - Long-Stroke Shakers

Air-cooled 29.4 - 52.9 kN (6600 - 11,890 lbf)

System Performance	T3034A	T4044M	T5444A
Sine Force Peak kN (lbf)	29.4 (6600)	39.2 (8810)	52.9 (11,890)
Random Force rms kN (lbf)	20.58 (4620)	39.2 (8810)	42.32 (9510)
Shock Force (6 ms) kN (lbf)	58.8 (13,210)	78.4 (17,620)	105.8 (23,780)
Frequency Range Hz	2-3000	5-2200	5-2300
Continuous Displacement mm (in)	100 (3.9)	100 (3.9)	100 (3.9)
Max Velocity m/s (in/s)	2.4 (94.4)	2.4 (94.4)	2.4 (94.4)
Max Acceleration Sine Peak m/s ² (g)	784 (80)	784 (80)	784 (80)
Armature Diameter mm (in)	340 (13.4)	445 (17.5)	445 (17.5)
Effective Armature Mass kg (lb)	37.5 (82.7)	50 (110)	68 (150)
Max Static Payload kg (lb)	500 (1100)	500 (1100)	800 (1760)



Simultaneous 3-Axis Shakers

In many cases, reproduction of a real-world environment requires a simultaneous 3-axis (X, Y, and Z axes) vibration testing system to reproduce the failure mode that the single-axis test cannot. The Sentek Dynamics' MA Series is the affordable solution to MIL-STD-810H, Method 527 requirements for multi-exciter (axis) testing.

- Up to 58.8 kN (13,210 lbf) Sine force capability per axis
- Working platform size up to 1200 x 1200 mm
- Three frequency ranges: High (H), Medium (M), and Low (L)

MA Series - Simultaneous 3-Axis Shakers

Air-cooled 9.8 - 58.8 kN (2200 - 13,210 lbf) Popular high-frequency (H) models shown below.

System Performance	MA-1000-4H	MA-2000-4H	MA-3000-4H	MA-5000-5H	MA-6000-5H
Sine Force Peak kN (lbf)	9.8 (2200)	19.6 (4400)	29.4 (6600)	49 (11,010)	58.8 (13,210)
Random Force rms kN (lbf)	6.86 (1540)	13.7 (3070)	20.5 (4600)	34.3 (7710)	43.1 (9680)
Frequency Range Hz	5-2000	5-2000	5-2000	5-2000	5-2000
Max Velocity m/s (in/s)	1 (39.4)	1.2 (47.2)	1.1 (43.3)	1.5 (59.1)	1.5 (59.1)
Max Acceleration Sine Peak m/s ² (g)	78.4 (8)	78.4 (8)	78.4 (8)	78.4 (8)	78.4 (8)
Platform Size mm (in)	400 (15.7)	400 (15.7)	400 (15.7)	500 (19.7)	500 (19.7)

Water-Cooled Vibration Test Systems*

* Systems tested & assembled in the USA coming soon. Contact Sentek Dynamics for availability.

High and Extra High-Force Shakers

Sentek Dynamics' H Series and E Series are water-cooled vibration testing systems designed for high-force, long-duration development and production testing of large aerospace, automotive and industrial components and assemblies. Like Sentek Dynamics' air-cooled systems, they provide cost-effective solutions to today's demanding test requirements. They are available in vertical only and mono-base configurations (integral slip table). Each system includes the shaker, amplifier, cooling unit, and interconnecting cables and hoses.



- Up to 392 kN (88,100 lbf) Sine force capability
- Static payload capability up to 6000 kg (13,220 lb)
- Working frequency up to 2500 Hz
- Pneumatic load support
- Air-isolated trunnion
- Motorized gearbox for shaker rotation standard

Available options:

- Air-isolation pads or mounts
- Automatic armature centering in static and dynamic modes
- Extended stroke available on most models
- Low and high-pressure slip tables for horizontal testing

H Series - High-Force Water-Cooled Shakers Water-cooled 63.7 - 156.8 kN (14,320 - 35,250 lbf)

System Performance	H6544A	H8044A	H10056A	H12056A	H16064A
Sine Force Peak kN (lbf)	63.7 (14,320)	78.4 (17,620)	98 (22,030)	117.6 (26,430)	156.8 (35,250)
Random Force rms kN (lbf)	63.7 (14,320)	78.4 (17,620)	98 (22,030)	117.6 (26,430)	156.8 (35,250)
Shock Force (6 ms) kN (lbf)	127.4 (28,640)	156.8 (35,250)	196 (44,060)	235.2 (52,870)	313.6 (70,500)
Frequency Range Hz	5-2500	5-2500	5-2400	5-2400	5-2200
Continuous Displacement mm (in)	51 (2.0)	51 (2.0)	51 (2.0)	51 (2.0)	51 (2.0)
Max Velocity m/s (in/s)	2 (78.7)	2 (78.7)	2 (78.7)	2 (78.7)	2 (78.7)
Max Acceleration Sine Peak m/s ² (g)	980 (100)	980 (100)	980 (100)	980 (100)	980 (100)
Armature Diameter mm (in)	445 (17.5)	445 (17.5)	560 (22.0)	560 (22.0)	640 (25.2)
Effective Armature Mass kg (lb)	60 (132)	80 (176)	100 (220)	100 (220)	160 (353)
Max Static Payload kg (lb)	1000 (2205)	1000 (2205)	1500 (3307)	1500 (3307)	2000 (4409)

E Series - Extra High-Force Water-Cooled Shakers Water-cooled 196 - 392 kN (44,060 - 88,100 lbf)

System Performance	E20064A	E30076A	E40086A
Sine Force Peak kN (lbf)	196 (44,060)	294 (66,090)	392 (88,120)
Random Force rms kN (lbf)	137 (30,790)	205 (46,080)	274 (61,590)
Shock Force (6 ms) kN (lbf)	392 (88,120)	588 (132,180)	784 (176,250)
Frequency Range Hz	5-2200	5-1900	5-1700
Continuous Displacement mm (in)	51 (2.0)	51 (2.0)	51 (2.0)
Max Velocity m/s (in/s)	2 (78.7)	1.8 (70.8)	1.8 (70.8)
Max Acceleration Sine Peak m/s ² (g)	980 (100)	980 (100)	980 (100)
Armature Diameter mm (in)	640 (25.2)	760 (29.9)	860 (33.9)
Effective Armature Mass kg (lb)	160 (353)	230 (507)	350 (772)
Max Static Payload kg (lb)	2000 (4409)	3200 (7055)	4000 (8,800)

TURN-KEY VIBRATION TEST SOLUTIONS

with Sentek Dynamics shakers and Crystal Instruments vibration control system.

Delivering what test engineers demand.

Sentek Dynamics has the unique ability to provide turn-key vibration testing solutions. Along with its sister company Crystal Instruments, Sentek Dynamics can offer a vibration test system complete with shaker and Spider vibration controller. This simplifies system purchasing and provides a single source for training and system support issues.



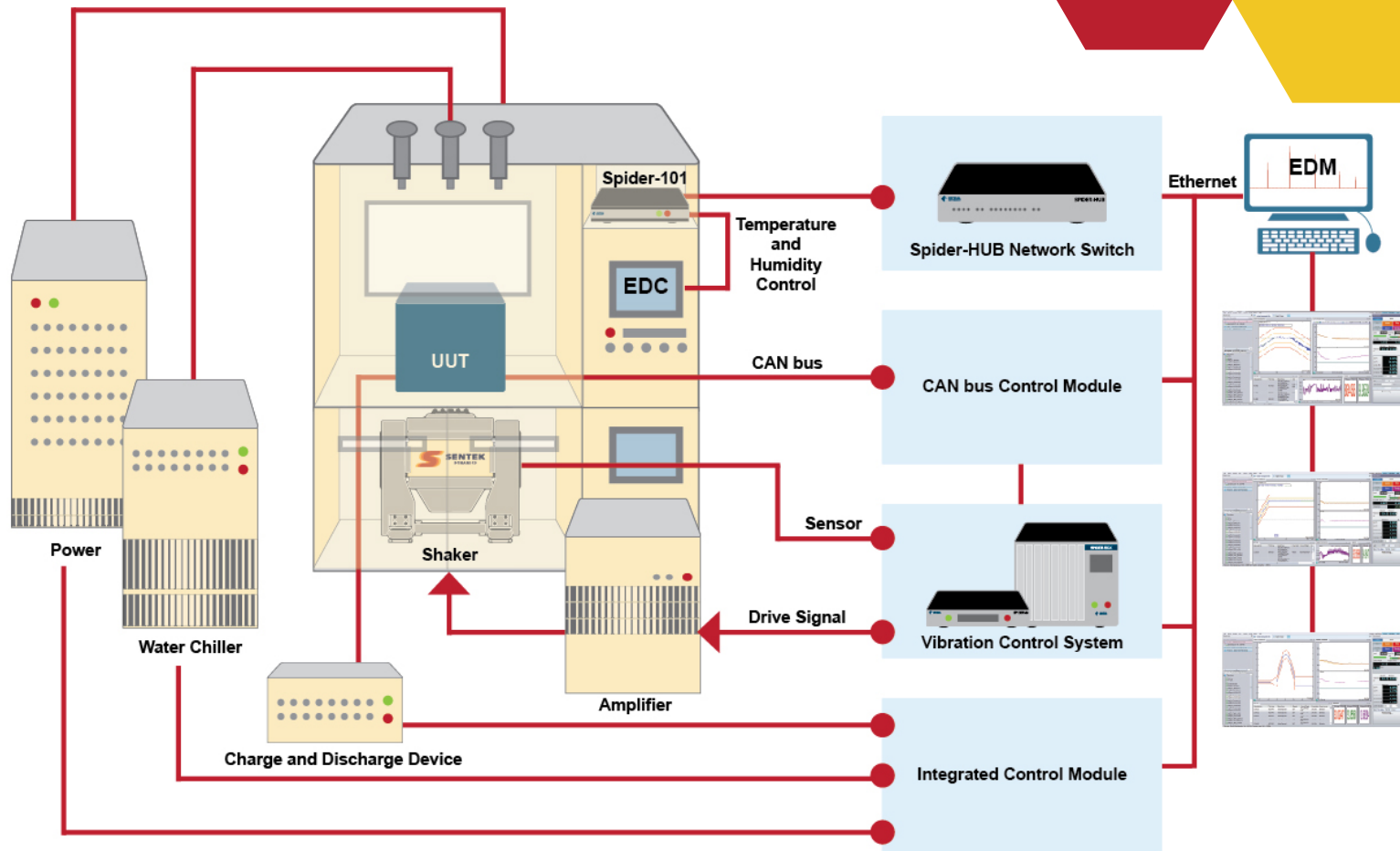

BATTERY TESTING

The continual innovation of battery technology for use in automotive, aerospace, and handheld devices demands increasingly comprehensive testing standards. Sentek Dynamics meets and exceeds those standards through our implementation of vibration, temperature, and humidity testing coupled with our CAN bus capable Crystal Instruments controllers. This enables comprehensive environmental testing representative of real-world conditions with monitoring and event actions taking place in a simplified information flow. Sentek Dynamics turn-key solution places powerful testing capabilities in the hands of customers that allows them to run intensive battery validation testing at their own pace to meet the industry's demanding requirements

AUTOMOTIVE

A customer base spanning from Tesla to Cummins and Rivian Automotive and American Axle & Manufacturing (AAM), Sentek Dynamics has demonstrated its ability to provide world-class vibration and environmental testing to established and emerging markets and the companies driving them. The scope of technology required to deliver successful products in the automotive industry is vast. The competitive pressure to deliver increasingly improved quality, safety, mileage, luxury, and economy is immense. Sentek Dynamics has adaptable solutions for every aspect of vibration and environmental testing. From simultaneous temperature, humidity, and vibration testing in THV chambers, to multiple shaker systems for vehicle chassis testing to simulate vehicle response to road vibrations, and CAN bus capable battery testing environments enabling energy charge and discharge during testing.

AEROSPACE

Development of space vehicles, satellites, fixed and rotary wing aircraft is a cutting-edge technology sector which demands and seeks out the most capable testing and control systems. Design verification of hardware and mathematical models is an all-important activity. The high cost of aerospace structures and the uniqueness of prototypes demand the most careful conduct of every controlled vibration investigation. Probing the edges of the unknown calls for extreme dynamic range and analysis flexibility in the measurement and testing hardware employed. Sentek Dynamics has delivered numerous systems to internationally recognized aerospace companies for use in development and verification testing, including **Raytheon, Boeing, Honeywell, and Lockheed Martin.**

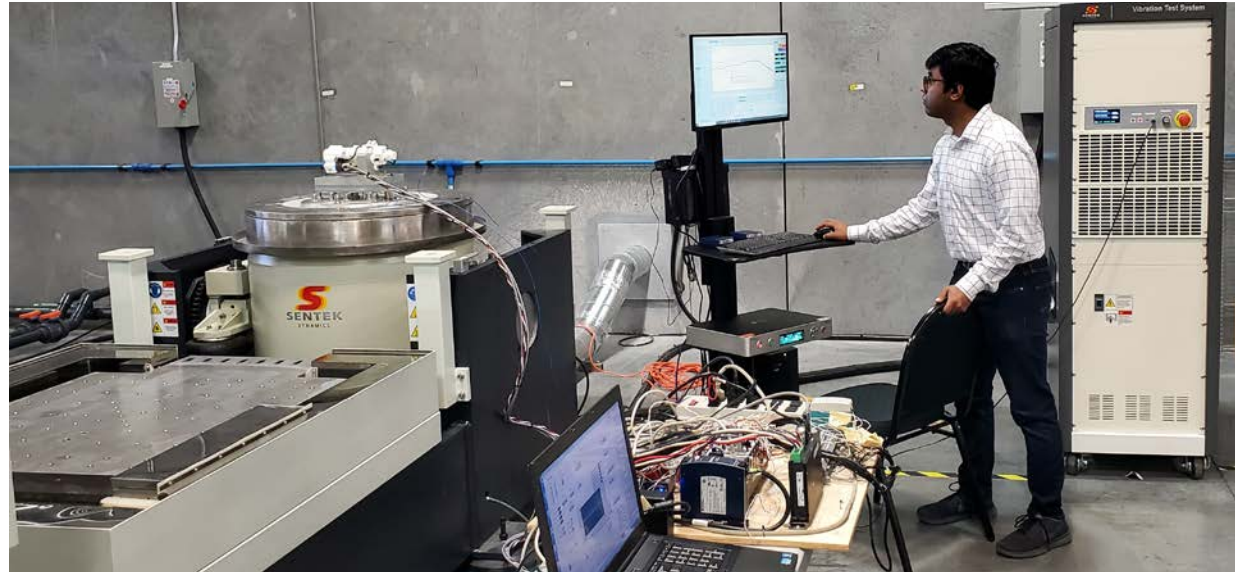

DEFENSE

The defense industry requires the utmost from each product it selects for use in the field and skies. Robust and safe design requires testing to match. Shock and vibration testing to ensure weapon safety, reliability and survivability during storage, transport, and deployment. In the case of missile payloads, vibration testing to prove the integrity of a missile during storage, transport, and firing. Sentek Dynamic systems are designed to meet military testing standards such as MIL-STD-750 and NAVMAT P-9492.

CUSTOM SYSTEMS

Cases arise where a device that is physically too large to fit on one shaker must be tested and validated. In these cases, the device can be mounted across multiple shakers to ensure the device is comprehensively tested. Shakers can be configured as Multiple-Exciter-Single-Axis (MESA) systems. This allows two or more shakers to split the loads required for a test, and synchronization through the EDM vibration software enables the shakers to output the same signal.





Spider systems are the fourth generation of vibration controllers - fully networked, built on Ethernet with IEEE 1588 time synchronization.

Crystal Instruments Spider vibration controllers are highly modular, distributed and scalable vibration control systems. The Spider systems represent the fourth generation of vibration control systems implementing advanced technology not seen in previous generations.

DSP CENTRALIZED ARCHITECTURE

DSP centralized hardware architecture runs real-time measurement and control processes on the front-end hardware, guaranteeing powerful and time efficient vibration testing, even with time critical tests. More importantly, any computer or network failure will not affect the vibration control.

LATEST HARDWARE DESIGN

Spider front-ends have voltage, IEPE and charge inputs

ideal for shock, vibration, and acoustic measurement, strain or general purpose voltage measurement. The internal flash memory stores test configuration data for controlling up to hundreds of channels simultaneously and stores real-time analysis data.

Multiple output channels provide various signal output waveforms that are synchronized with the input sampling rate. The scalable architecture allows users to employ as many as 512 input channels for the utmost spatial resolution with a sampling rate of 102.4 kHz and spectra control up to 12,800 lines.

SIMPLE NETWORK CONNECTION

Ethernet connectivity and wireless network routers allows Spiders to be located far from a single host PC.

This distributed structure greatly reduces noise and electrical interference in the system.

MULTIPLE MODULE TIME SYNCHRONIZATION

The Spider is built on IEEE 1588 Precision Time Protocol (PTP) time synchronization technology, allowing remote input modules to connect solely by Ethernet while still providing sampling and triggering synchronizations with an accuracy of 50 ns.

All input channels across the system are amplitude matched within 0.1 dB and phase matched within 1° over a 20 kHz bandwidth. With this unique technology and high-speed Ethernet data transfer, the distributed components on the network truly act as one integrated system.



CAN bus

The Controller Area Network or CAN bus capability of the Spider controllers from CI simplifies test setup and adds functionality to the test procedure, enabling battery condition monitoring during combined environmental testing and programmable event action rules to take additional action once specified conditions are reached, such as emergency shutdown.

EDM Cloud

EDM Cloud is a premium web-hosted service provided for users to monitor the live status of vibration tests across multiple Spider controllers and is compatible with vibration, temperature, and humidity testing. System test parameters and profiles can be uploaded and downloaded via the EDM Cloud, allowing system access, configuration, and trouble-shooting from any location via a secure, password-protected user account. EDM Cloud can also be deployed on local servers within an organization's network, further limiting the scope of information exchange and increasing the data security, particularly useful for monitoring environments tests involving classified information.

Spider Vibration Control Software Modules

<i>Random Vibration Control</i>	<i>Classical Shock Control</i>	<i>Non-Acceleration Control</i>
<i>Sine on Random Control</i>	<i>Transient Time History Control (TTH)</i>	<i>Real-Time Sine Reduction</i>
<i>Random on Random Control</i>	<i>Shock Response Spectrum (SRS) Synthesis and Control</i>	<i>Sensor Calibration</i>
<i>Swept Sine Control</i>	<i>Time Waveform Replication</i>	<i>Front-end Calibration Tool (FECT)</i>
<i>Multi-Sine Control</i>	<i>Waveform Editor</i>	<i>Data Transfer Tool</i>
<i>Total Harmonic Distortion (THD) Measurement for Sine</i>	<i>Multi-Shaker Control for Sine or Random</i>	<i>Dynamic Signal Analysis & Post Processing Function</i>

High Performance Vibration Test System*

* Systems tested & assembled in the USA coming soon. Contact Sentek Dynamics for availability.



P Series High-Performance Shakers

Air & Water-cooled 34.3 - 78.4 kN (7710 - 17,620 lbf)

System Performance	P3532M	P6044A	P8044A
Sine Force Peak kN (lbf)	34.3 (7710)	58.8 (13,210)	78.4 (17,620)
Random Force rms kN (lbf)	24 (5390)	39.2 (8810)	78.4 (17,620)
Shock Force (6 ms) kN (lbf)	68.6 (15,420)	117.6 (26,430)	156.8 (35,250)
Frequency Range Hz	2-3000	5-2300	2-2500
Continuous Displacement mm (in)	51 (2.0)	51 (2.0)	51 (2.0)
Max Velocity m/s (in/s)	2 (78.7)	2 (78.7)	2 (78.7)
Max Acceleration Sine Peak m/s ² (g)	1470 (150)	1470 (150)	1470 (150)
Armature Diameter mm (in)	320 (12.6)	340 (13.4)	445 (17.5)
Effective Armature Mass kg (lb)	23.3 (51.4)	40 (88.2)	53 (116.8)
Max Static Payload kg (lb)	500 (1100)	600 (1320)	800 (1760)

High-Performance Shakers

With a max acceleration of 150 g Sine and a range of 34.3 to 78.4 kN (7710 to 17,620 lbf) Sine force peaks, the Sentek Dynamics' P Series vibration testing systems offer exceptional performance at an affordable price. The P Series is available in vertical and horizontal operation with an optional slip table.

- 78.4 kN (17,620 lbf) Sine force capability
- Max acceleration 150 g Sine peak
- Max static payload capability 800 kg (1760 lb)
- Minimum frequency of 2 Hz with a working frequency up to 3000 Hz
- Pneumatic load support
- Air-isolated trunnion

Available options:

- Air-isolation feet, pads, or mounts
- Automatic armature centering in static and dynamic modes
- Low and high-pressure slip tables for horizontal testing
- Motorized gearbox for shaker rotation

Mono-base Slip Tables*

** Systems tested & assembled in the USA coming soon. Contact Sentek Dynamics for availability.*

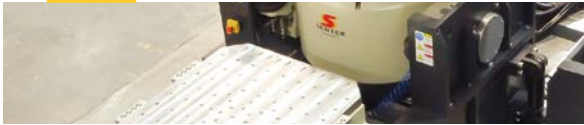

With today's demanding test requirements there is an increasing need for slip tables to facilitate testing in a horizontal position. Sentek Dynamics offers mono-base slip tables in low and high-pressure designs in standard sizes ranging from 300 mm (12 inches) to 2500 mm (98 inches). Custom sizes are also available including expandable slip tables when a larger mounting area is occasionally required.

In a mono-base configuration the shaker and slip table share a structural steel body that enables rapid conversion between vertical and horizontal positions, and the accurate alignment of the shaker relative to the slip table when rotated to the horizontal position.

LST Series

Sentek Dynamics' low-pressure LST Series slip tables provide an affordable solution to horizontal testing requirements. LST Series slip tables utilize V-groove bearings to guide the magnesium slip plate over an oil-film on a precision ground granite slab. Oil from an integral hydraulic power supply is dispersed through ports in the granite slab under the magnesium slip plate.

- Affordable solution for horizontal testing
- Integral hydraulic pump, reservoir and filter

HST Series

High-pressure slip tables utilizing T-slot bearings designed for testing heavy payloads with a high center of gravity. The HST Series provides the highest

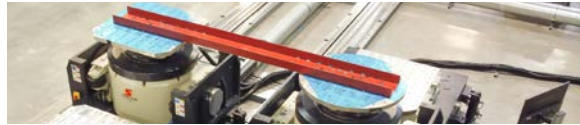

resistance to pitch, roll and yaw over-turning moments.

- Optimum solution for testing heavy payloads with a high center of gravity
- Separate hydraulic power supply and oil cooler
- More reliable than hydrostatic journal bearings
- Lower maintenance costs over an extended period of time

LST and HST Series - Mono-base and Slip Tables

Series Designation	Max Payload kg (lb)	Slip Plate Thickness mm (in)	Slip Plate Mass kg (lb)	No. of Bearings	Total Bearing Mass kg (lb)	Total Slip Table Mass kg (lb)	Over-Turning Moments		
							Pitch kN-m (lbf-ft)	Roll kN-m (lbf-ft)	Yaw kN-m (lbf-ft)
LST300A	100 (220)	25 (1.0)	9 (19.8)	1	2 (4.4)	9 (19.8)	0.5 (369)	0.5 (369)	0.2 (148)
LST400M	150 (331)	25 (1.0)	10 (22.0)	1	2 (4.4)	10 (22.0)	0.875 (645)	0.875 (645)	0.2 (148)
LST500MT	150 (331)	25 (1.0)	14 (30.9)	2	4 (8.8)	14 (30.9)	1.538 (1134)	1.538 (1134)	0.2 (148)
LST500M	300 (661)	45 (1.8)	24 (52.9)	2	4 (8.8)	24 (52.9)	1.538 (1134)	1.538 (1134)	0.2 (148)
LST600M	300 (661)	45 (1.8)	34 (75.0)	2	4 (8.8)	34 (75.0)	2.2 (1623)	2.2 (1623)	0.2 (148)
LST700M	300 (661)	45 (1.8)	48 (105.8)	2	4 (8.8)	48 (106)	3 (2213)	3 (2213)	0.2 (148)
LST800M	400 (882)	45 (1.8)	60 (132.3)	2	4 (8.8)	60 (132)	3.9 (2876)	3.9 (2876)	0.2 (148)
LST900M	400 (882)	45 (1.8)	78 (172.0)	2	4 (8.8)	78 (172)	4.9 (3614)	4.9 (3614)	0.2 (148)
LST1000M	500 (1102)	50 (2.0)	105 (231.5)	4	8 (17.6)	105 (231)	6.6 (4868)	6.6 (4868)	1.4 (1033)
LST1200M	500 (1102)	50 (2.0)	144 (317.5)	4	8 (17.6)	144 (317)	9.1 (6712)	9.1 (6712)	1.54 (1136)
LST1500M	800 (1764)	50 (2.0)	246 (542.3)	6	12 (26.5)	246 (542)	14.75 (10,879)	14.75 (10,879)	3.15 (2323)
LST1800M	1000 (2205)	60 (2.4)	362 (798.1)	6	12 (26.5)	362 (798)	20.7 (15,268)	20.7 (15,268)	3.78 (2788)
LST2000M	1000 (2205)	60 (2.4)	478 (1053.8)	8	16 (35.3)	478 (1054)	27.2 (20,062)	27.2 (20,062)	5.6 (4130)
HST800M	8000 (17,637)	45 (1.8)	81 (178.6)	4	22 (48.5)	81 (179)	45 (33,190)	38 (28,027)	8.6 (6343)
HST900M	8000 (17,637)	45 (1.8)	95 (209.4)	4	22 (48.5)	95 (209)	45 (33,190)	38 (28,027)	8.6 (6343)
HST1000M	10,000 (22,046)	50 (2.0)	145 (319.7)	9	49.5 (109.1)	145 (320)	90 (66,381)	82 (60,480)	15 (11,063)
HST1200M	10,000 (22,046)	50 (2.0)	183 (403.4)	9	49.5 (109.1)	183 (403)	112 (82,607)	98 (72,281)	17 (12,539)
HST1500M	15,000 (33,069)	50 (2.0)	292 (643.8)	16	88 (194.0)	292 (644)	200 (147,512)	156 (115,060)	24 (17,702)
HST1800M	15,000 (33,069)	50 (2.0)	384 (846.6)	16	88 (194.0)	384 (847)	224 (165,214)	178 (131,286)	28 (20,652)
HST2000M	18,000 (39,683)	60 (2.4)	598 (1318.4)	25	137.5 (303.1)	598 (1318)	238 (175,540)	195 (143,825)	36 (26,552)
HST2500M	25,000 (55,116)	60 (2.4)	909 (2004)	36	198 (436.5)	909 (2004)	265 (195,454)	202 (148,988)	45 (33,190)

Head Expanders and Fixtures

Sentek Dynamics provides a wide variety of standard head expanders with optional guidance and load support configurations.

For payloads with large footprints, head expanders can be specified that increase the mounting area. Load support and guidance ensures the armature stays aligned and centered during operation.

Cube, L-type & T-type fixtures for testing multiple components are available to accommodate multi-axis testing without a slip table.

Power Amplifiers*

* Systems tested & assembled in the USA coming soon. Contact Sentek Dynamics for availability.

Digital Switching Power Amplifiers

Sentek Dynamics' modular digital switching (Class D) PA Series power amplifiers are air-cooled and designed for maximum reliability and efficiency. Rated power outputs range from 2 to 400 kVA. All amplifiers are provided with locking casters and BNC connectors on the front and rear panels of the logic control module.

The power supply for shaker field coils and ancillary units are provided by the amplifier. Integrated ancillary units can be part of the start-up and stop sequences.

The logic control module with an LCD display and interactive microprocessor provides a user friendly interface and compatibility with most electrodynamic shakers. System status is continuously displayed and fault events are displayed on the LCD panel. Any over-current, over-travel, over-temperature or short-circuit will trigger an immediate system interrupt.

A remote control panel is available that duplicates the features and functions of the logic control module front panel.

Designed to reduce the loss of power in the event of a failed component, each 12 kVA power-module consists of two independent 6 kVA sub-modules utilizing the latest in MOSFET technology. Ample air-cooling is provided to allow continuous operation at high-output levels.

- LCD panel displays system status with instantaneous output voltage and current
- Conversion efficiency greater than 90%
- High modulation switching frequency
- High signal to noise ratio
- Low total harmonic distortion
- Certified to meet applicable CE requirements for EMC and safety

Crystal Instruments Remote Amplifier Control Software

The amplifier control software is designed for specific Sentek Dynamics amplifier models. It features a flexible display, a userfriendly UI, and an interlock feature to prevent or stop the controller from running when the amplifier is not in an operating state.



Linear Power Amplifiers

Sentek Dynamics' LA Series compact linear power amplifiers are designed to be used with Sentek Dynamics' line of permanent magnet desk top and modal shakers. They are adaptable to other manufacturer's permanent magnet shakers and applications requiring a linear amplifier. The LA Series of amplifiers is available with outputs ranging from 100 to 800 VA.

Replacement Amplifiers



Sentek Dynamics offers a full line of high-performance digital switching power amplifiers. These amplifiers are offered as replacements for older vacuum tube amplifiers and bipolar transistor amplifiers.

Many vibration test systems purchased over the last 40 years include low-efficiency water-cooled power amplifiers housed in large multi-bay cabinets. These old technology amplifiers consume large amounts of 3-phase electrical power, occupy excessive amounts of valuable floor space and require environmentally "unfriendly" watercooling systems. All of these problems have one solution – a new highly efficient, air-cooled digital switching power amplifier from Sentek Dynamics.



Authorised distributor

In Australia:

For customer service, call 1300-735-292
To email an order, ordersau@thermofisher.com
To order online: thermofisher.com

In New Zealand:

For customer service, call 0800-933-966
To email an order, ordersnz@thermofisher.com
To order online: thermofisher.com

ThermoFisher
SCIENTIFIC



© Sentek Dynamics, 04-2022

Specifications are correct at the time of publication. In keeping with our commitment to continuous product improvement, the information herewith is subject to change. Sentek Dynamics reserves the right to amend specifications without prior notice.