



What you need to know about  
mercury emissions, regulations, and monitoring

# Table of contents



## Overview

Mission.....	04
Mercury is used in many products/processes.....	05



## Global Regulations

Global air quality regulations.....	07
Global Hg regulations.....	08
Europe.....	09
United States.....	11

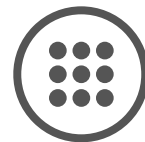

## Gas Analyzer Technology

Who needs to monitor mercury emissions.....	14
How is mercury monitored.....	15
How do mercury analyzers work.....	16
Watson Mercury Speciation System.....	17
Mercury Freedom CEM System.....	18
Probes.....	19
Other emissions monitoring systems.....	20



# Overview

# Mission: Enable our customers to make the world healthier, cleaner and safer

Ensuring clean air requires a global collaborative effort. Governmental agencies are working harder than ever toward creating regulations that minimize the release of pollutants and harmful toxins, including mercury, in the air.

Waste incinerator municipalities, cement producers, and coal-fired and combustion power plants are especially affected by these regulations and are utilizing the latest technology to monitor and reduce emissions, reduce public risk, and protect the environment.



# Mercury is used in many products/processes



- production of batteries
- thermostats
- cameras
- cathode tubes
- calculators
- small appliances
- medical lab chemicals
- chlorine production
- catalyst in production of urethane polymers for plastics
- mercury vapor lamps
- switches
- hearing aids

**9 Fast Facts About Mercury**

**Atomic Number 80**

Alloys easily with many metals, such as gold, silver, and tin. These alloys are called amalgams.

Named after the planet Mercury.

Can be found in these End of Use Products:

- Batteries & Switches
- Cosmetics & Skin Creams
- Thermometers
- Dental amalgams
- Medical devices

Found in tubes in Egyptian tombs dated from 3500 BC.

Mercury's main source is cinnabar ore (pictured here).

Sometimes called quicksilver.

Highly toxic, very volatile element that must be handled with care.

Poor conductor of heat but fair conductor of electricity.

Mercury is a heavy, silvery-white liquid metal and the only common metal that stays in liquid form at ordinary temperature.

**Hg**  
Mercury

Delivering Value to the Mining Industry  
www.thermoanalytical.com/mercury

**Thermo**  
SCIENTIFIC



# Global Regulations

# Global air quality regulations

Global businesses must navigate a complex and constantly changing set of requirements from US and China EPAs to EU directives related to air and water pollution.

- Utility MATS
- ICI Boiler MACT
- 40 CFR Parts 60 and 63
- Fugitive Emissions
- Cement MACT/NESHAP
- EEA and CEPA 1999
- Part 74 Personal Sampler
- NSPS Sub Part Ja
- \*LCP BREF and \*\*WI BREF



\*LCP=large combustion plan    \*\*WI=waste incinerator

As mercury regulations evolve, our applications specialists may publish new applications notes or eBooks. Let us know your preferences we'll send information that is valuable to you.



# Global Hg regulations

## Current and Upcoming

- US EPA was the first country to release Hg rule in 2006.
- Chinese MEP to release new Hg emissions standard during China's 13th or 14th Five-Year Plan.
- India released new Hg emissions standards in 2015.
- European Commission plans to release New Hg regulations for large combustion plants to be compliant by 2021 in 28 countries. Mercury regulation for Waste incinerator to come in 2019 and to be compliant by 2023.

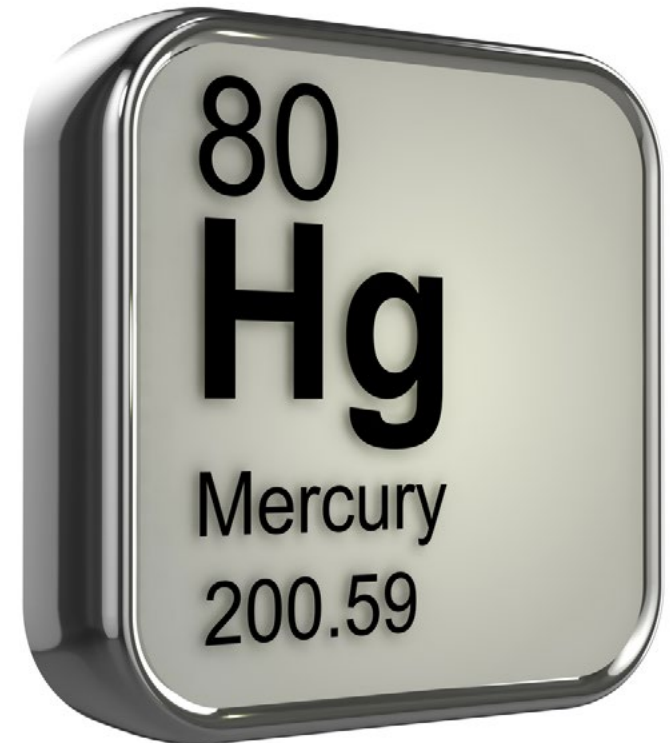



# Europe

Current EU policy bans exports of mercury, provides for the storage of mercury waste, restricts the use of mercury in various products, and seeks to address pollution caused by it.

More than half of the 33 European Economic Area countries exceed critical loads of mercury across an estimated 90% of their ecosystem area.

**Source:** [http://env-health.org/IMG/pdf/13.\\_airmercury\\_final.pdf](http://env-health.org/IMG/pdf/13._airmercury_final.pdf)

Directive 2004/107/EC of the European Parliament and of the Council relating to arsenic, cadmium, mercury, nickel and polycyclic aromatic hydrocarbons in ambient air (Fourth Daughter Directive).

Task Force on Hemispheric Transport of Air Pollution (HTAP), jointly led by the US and the EU, which has developed detailed findings for ozone, particulate matter, mercury, and persistent organic pollutants.



# EU compliance standards

## Industrial Emissions Directive (IED)

- Replacing 7 previous regulations to further limit the emissions of pollutants
- Calls for Best Available Techniques (BAT) to be rewritten by committees

## Large Combustion Plant (LCP) BREF

- BAT REFERENCE Document (BREF)
- Establishes Associated Emissions Levels (AELs) for plants over 50MW
- Adopted July 2017

## Waste Incinerator (WI) BREF

- Establishes Will establish Associated Emissions Levels (AELs)
- Final meeting for review of waste incineration BREF

## Cement, Lime, and Magnesium Oxide (CLM) BREF

- Establishes Associated Emissions Levels (AELs)
- Germany's limit for 20  $\mu\text{g}/\text{nm}^3$  since January 2016
- In draft review as of April 2018

\*Source - <http://www.globalcement.com/magazine/articles/845-global-cement-emissions-standards>

Updates to permitting processes with new Emissions Limit Values (ELVs) within four years of BREF adoption

# United States



**The US was the first country to release an Hg rule in 2006**

The law includes special provisions for dealing with air toxics emitted from utilities, giving the EPA the authority to regulate power plant mercury emissions. The Agency can do this by establishing “performance standards” or “maximum achievable control technology” (MACT), whichever the Agency deems most appropriate.

The Clean Air Act requires the EPA to set National Ambient Air Quality Standards (40 CFR part 50) for pollutants considered harmful to public health and the environment. The Clean Air Act identifies two types of national ambient air quality standards.

**Primary standards** provide public health protection, including protecting the health of “sensitive” populations such as asthmatics, children, and the elderly.

**Secondary standards** provide public welfare protection, including protection against decreased visibility and damage to animals, crops, vegetation, and buildings.

The Clean Air Act regulates 188 air toxics, also known as “hazardous air pollutants.” Mercury is listed as one of these air toxics. The Act directs the EPA to establish technology-based standards for certain sources that emit these air toxics. Those sources also are required to obtain Clean Air Act operating permits and to comply with all applicable emission standards.

# United States

## USA Mercury Air Toxics Standards (MATS) Rule

- First ever US EPA national emission standards for air toxics at new and existing power plants.
- Clean Air Mercury Rule (CAMR) was the first rule implemented in 2006 and got vacated in 2009.
- Utility MATS Rule began on April 16, 2015.
- Hg CEMS Monitoring Plan Section 7.2.3.1, App. A Subpart UUUUU.
- Sets emission rate standards (input or output) for mercury.
- Provides guidance for options for Control Technologies such as Activated Carbon Injection (ACI).

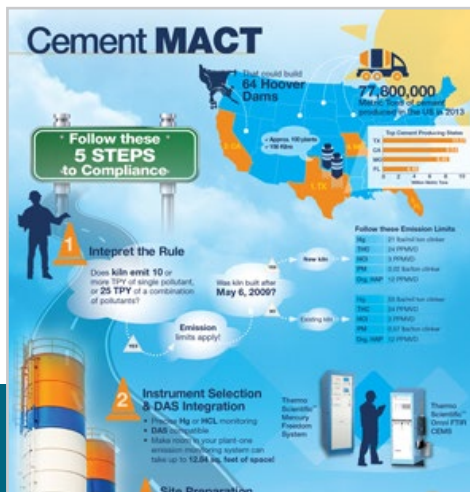

**MATS website:** <http://www.epa.gov/mats/>



# Gas Analyzer Technology

# Who needs to monitor mercury emissions

- Waste incinerator municipalities
- Cement manufacturers
- Combustion plants
- Power plants
- Other stationary sources



# How is mercury monitored

“Monitoring is a general term for on-going collection and use of measurement data or other information for assessing performance against a standard or status with respect to a specific requirement.

With regards to air quality regulatory requirements, there are two basic types of monitoring with two different functions:

- Ambient air quality monitoring collects and measures samples of ambient air pollutants to evaluate the status of the atmosphere as compared to clean air standards and historical information.
- Stationary source emissions monitoring collects and uses measurement data (or other information) at individual stationary sources of emissions (i.e., facilities, manufacturing plants, processes, emissions control device performance, or to verify work practices).
- Stationary source emissions monitoring is required to demonstrate that a source is meeting the requirements in Federal rules or in State rules that are part of a State Implementation Plan (SIP). Most monitoring that stationary sources must conduct is related to specific regulation resulting from the Clean Air Act (CAA).”

**Source:** EPA Technology Transfer Network, Clearinghouse for Inventories & Emissions Factors



# How do mercury analyzers work

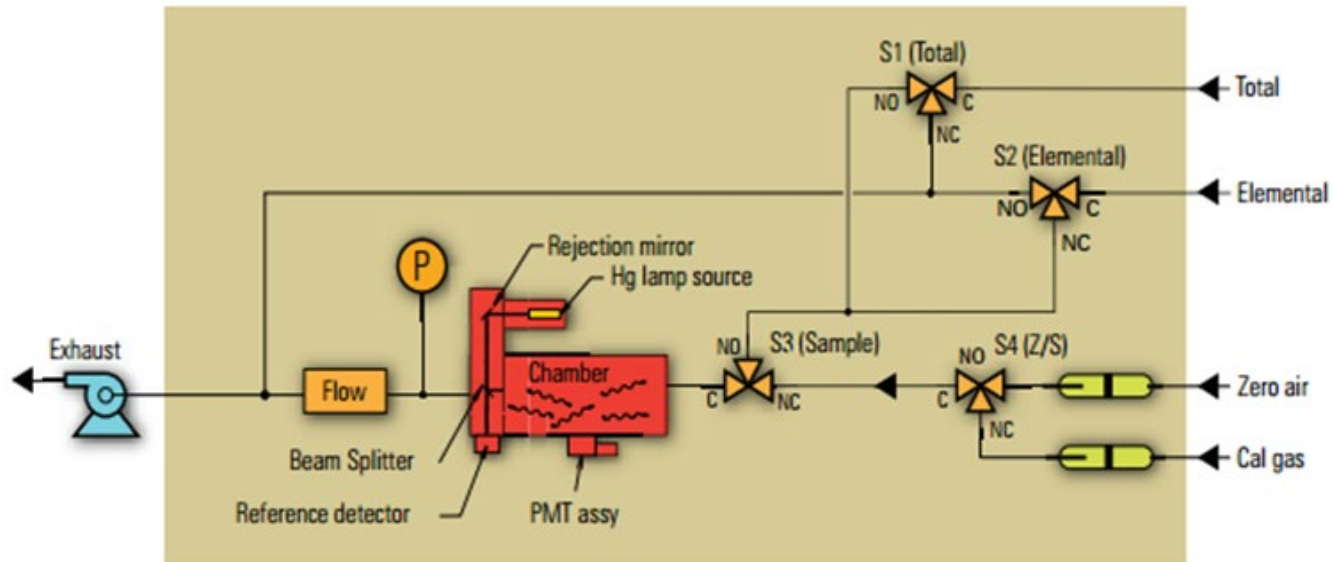

This example of a mercury analyzer is based on the principle that Mercury (Hg) atoms absorb ultraviolet (UV) light at 254 nm, become excited, then decay back to the ground energy state, emitting (fluorescing) UV light at the same wavelength. Specifically,  $\text{Hg} + h\nu(254\text{nm}) \rightarrow \text{Hg}^* \rightarrow \text{Hg} + h\nu(254\text{nm})$ . It is one of four major components of a total mercury monitoring system. The analyzer uses an advanced cold vapor atomic fluorescence technology to provide continuous sample measurement, with no additional gases or accumulations required and virtually no interference from SO<sub>2</sub>.



# Watson Mercury Speciation System

The Thermo Scientific Watson MSS is the solution for tightening mercury regulations in the European Union. The decrease of certified ranges mean Coal, Waste-to-Energy, and Cement plants need measurement at lower levels. The Watson MSS is packaged in an IP55 lockable cabinet, with ports on the probe for QAL 2 maintenance checks, and 95+% uptime availability of data. With the ability to speciate, or decipher, between the two main states of Mercury, the Watson Mercury Speciation System not only helps you measure, but take action for total mercury compliance.

- Continuous, real-time measurement of Hg
- Reliable measurement in ambient temperature ranges of -20C to +50C
- Total and Elemental mercury measurement for emissions controls
- Cold vapor atomic fluorescence analyzer  
High sensitivity with virtually no interference from SO<sub>2</sub>
- IP 55 rated and insulated enclosure with Heat and Air Conditioning  
Allows installation of the system in a wide variety of ambient conditions
- NIST Traceable Mercury Calibrator  
Elemental Mercury vapor generator performs NIST traceable span check



# Mercury Freedom CEM System

The Mercury Freedom System offers high measurement sensitivity, fast response times and robust operation in harsh environments through a simple design that closely resembles a traditional wet-basis dilution extractive CEMS. The system is capable of measuring elemental (HgO), ionic (Hg<sup>2+</sup>) and total mercury (Hg) in exhaust stacks through the use of Cold Vapor Atomic Fluorescence technology.

- High Sensitivity CVAF bench operates under a superior vacuum.
- No interferences with acidic gases like SO<sub>2</sub>.
- Truly continuous real-time response.

## The Mercury Freedom System consists of a:

- Sampling probe at the stack.
- A heated umbilical line for sample transport.
- Model 80i Analyzer.
- Model 81i Calibrator.
- Model 82i Probe Controller.
- Standard 19" rack, within an accessible temperature-controlled location.
- Air Clean-up System to generate contaminant, oil-free dilution air, and a sample pump.



# Probes

Thermo Scientific offers two types of Mercury Probes for varying plant and application specifications. The applications and quoting team works directly with customers to select the probe which best fits their needs and application.

- The 83i probe is a robust and reliable probe that can handle high particulates and carbon carryover from plants with loss of ignition or upstream of pollution controls.
- The model 85 probe is a simple and compact probe ideal for a wet scrub plant with Flue-Gas Desulfurization (FGD) in a stack or compliance install location.



- Dry converter located in probe eliminates the transport of oxidized mercury.
- Reduced umbilical temperature extends life of umbilical line and reduces service needs.
- Liquid standard port for use in accordance with QAL 3 monitoring and Annual Functional Testing (AST).

# Other emissions monitoring systems

## Continuous Emissions Monitoring Systems (CEMS)

Comply with US EPA guidelines while meeting your own specific monitoring needs with the customizable Thermo Scientific™ Continuous Emissions Monitoring Systems. These systems are designed to meet US EPA 40CFR Parts 60 and 75 standards while providing unsurpassed sensitivity, accuracy and reliability.

### Comply with key features:

- A wide variety of gas analyzers, probes, and other critical CEMS components.
- System integration capabilities.
- Standard connectivity options.
- Configurability to measure various combinations of SO<sub>2</sub>, NO<sub>x</sub>, CO, TRS, NH<sub>3</sub>, HCl, THC, Hg, CO, O<sub>2</sub>, PM, H<sub>2</sub>S, Flow, Opacity.
- Measurement ranges for most criteria pollutants from 0 to 10 ppm to 0 to 10,000 ppm full scale.

### Recommended for:

- Power plants, waste incinerators, cement plants, refineries, turbines, and other stationary sources.
- Lime kilns, power boilers, cement kilns, co-generation, incinerators, wood-waste boilers, and recovery boilers.



# Thermo Fisher Scientific environmental & process monitoring

EPM instruments are used in a wide variety of customer applications and market segments from utilities, state and governmental agencies, oil and gas, mining, iron and steel, pharmaceutical manufacturing, cement, power generation, and other industrial applications. Our instruments make the world healthier, cleaner, and safer and are used globally to regulate and improve air quality along with keeping miners safe and minimize their exposure to particulates. Also, our products enable our customers to maximize efficiency in their processes by providing accurate, precise, and comprehensive data.



## About Thermo Fisher Scientific

Thermo Fisher Scientific is the world leader in serving science, with revenues of more than \$24 billion and approximately 70,000 employees globally. Our mission is to enable our customers to make the world healthier, cleaner and safer. We help our customers accelerate life sciences research, solve complex analytical challenges, improve patient diagnostics, deliver medicines to market and increase laboratory productivity. Through our premier brands – Thermo Scientific, Applied Biosystems, Invitrogen, Fisher Scientific and Unity Lab Services – we offer an unmatched combination of innovative technologies, purchasing convenience and comprehensive services.

For additional information or to request a quote, please click below.

