

Lead discovery

Orbitrap Exploris GC 240 Mass Spectrometer

Benefits

- Premium quantitative and qualitative performance with the fast-scanning High-Field Thermo Scientific™ Orbitrap™ mass analyzer
- Best-in-class resolving power, mass accuracy, sensitivity, and dynamic range
- Compatible Thermo Scientific Compound Discoverer software for chemometric analysis
- EI/CI Thermo Scientific™ ExtractaBrite™ ion source removable under vacuum through vacuum interlock
- NeverVent™ technology for Vent-free ion source and column exchange
- VeV low electron energy acquisition for increased molecular ion production

The Thermo Scientific™ Orbitrap Exploris™ GC 240 hybrid quadrupole Orbitrap mass spectrometer is a Thermo Scientific™ quadrupole-Orbitrap™ mass spectrometer based on proven hardware and instrument control software designs of the next-generation Thermo Scientific mass spectrometers and incorporates extensive customer and service engineer feedback.



The Orbitrap Exploris GC 240 takes research capability to a new and unprecedented level of performance to accelerate scientific discovery. With a unique ability to deliver the very highest data quality, the most complex analytical challenges are simplified. By delivering uncompromising qualitative and quantitative performance, the system provides the flexibility to address the demands of scientific research laboratories for compound identification and quantitation. From discovery profiling, metabolomics and applied quantification, scientists gain unparalleled access to information rich data and results with ease.

Hardware features

Ion source

- Thermo Scientific™ ExtractaBrite™ Electron Ionization (EI) source
- Ion source includes ion volume, repeller, source lenses, RF lens and dual filaments in all ionization modes, programmable from 50 °C to 350 °C
- VeV tuning allows optimized low electron energy acquisition down to 8 eV
- Chemical Ionization (CI) source for acquisition with Positive Ion Chemical Ionization (PCI) and Negative Ion Chemical Ionization (NCI)
- Remove entire ion source or change to CI source in under 2 minutes without venting
- NeverVent™ technology for Vent-free ion source and column exchange with patented source plug

Combination EI/PCI/NCI ion volume can be used without need for source interchange.

Ion optics

Advanced active beam guide (AABG)

Axial field reduces noise by preventing neutrals from entering the quadrupole mass filter using double bent design geometry.

Advanced quadrupole technology (AQT)

- Segmented quadrupole mass filter for precursor ion selection with variable precursor isolation width from 0.4 to 1,200 Da
- MS/MS and SIM precursor ion selection with high transmission from m/z 30 to 2,000

Ion-routing multipole (IRM)

- Robust ion trapping for higher energy collisional dissociation (HCD)
- Nitrogen collision gas

Automatic gain control (AGC)

Reliable AGC measurements for controlled injection of the number of ions.

Thermo Scientific Orbitrap mass analyzer

- High-Field Orbitrap mass analyzer
- Low noise detection pre-amplifier
- 4 kV central electrode voltage

Vacuum system

- A compact single turbo pump design providing the adequate vacuum in five stages for the aluminum high-vacuum analyzer chambers
- Advanced vacuum technology reduces pressure in the ultra-high vacuum regions, enhancing transmission of ions to the Orbitrap mass analyzer

Optional hardware

Direct sample probe system option

- Switch to probe <3 min with GC undisturbed
- Available in two styles: rapid heating filament Direct-Exposure Probe (DEP, capable of flash vaporization or pyrolysis at up to 1,600 °C) or slower volatilization Direct-Insertion Probe (DIP, capable of accommodating powders and solid samples in a quartz or aluminum crucible) up to 450 °C

Orbitrap Exploris GC 240 mass spectrometer ion path

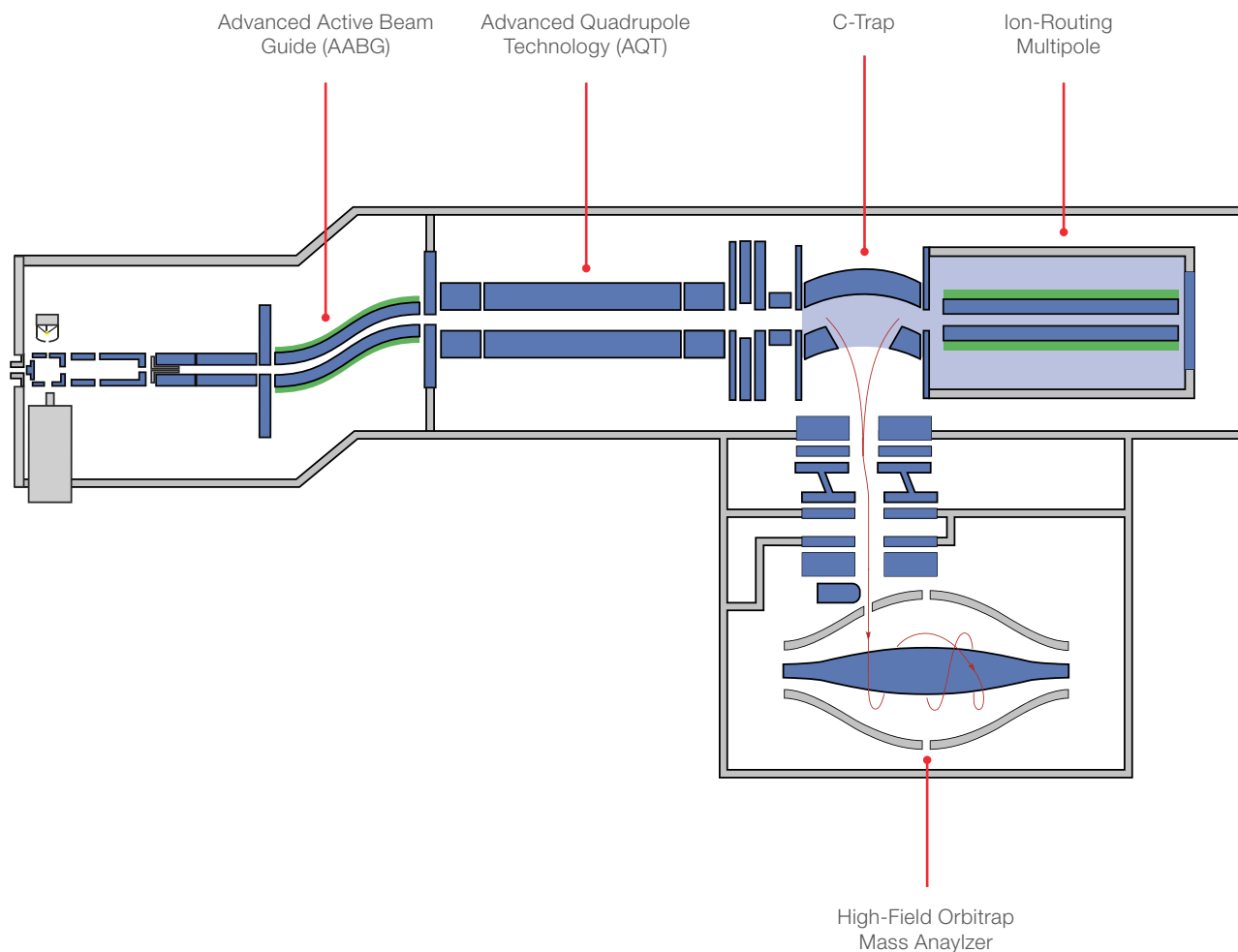

Performance specifications	
Mass range	m/z 30–3,000
Orbitrap mass analyzer resolution	Up to 240,000 at m/z 200
Scan rate*	Up to 40 Hz at resolution setting 7,500 at m/z 200
Mass accuracy*	External calibration achieves <3 ppm RMS drift over 24 hours Internal lock mass calibration achieves <1 ppm RMS drift over 24 hours
Sensitivity	EI: 100 fg octafluoronaphthalene on column, scanning m/z 50–300, S/N 10,000:1 EI IDL**: 6 fg octafluoronaphthalene derived at the 99% confidence level PCI: 10 pg benzophenone on column, scanning m/z 80–230, S/N 150:1
Dynamic range	>10 ⁶ analytical dynamic range* >5,000 within a single Orbitrap mass analyzer spectrum
Polarity switching	One Full Scan cycle*** <700 ms equals >1.4 Hz One tSIM Scan cycle*** <600 ms equals >1.6 Hz
Multiplexing	Up to 20 precursors per scan

* Under defined conditions

** Demonstrated at installation with purchase of Thermo Scientific™ TriPlus™ RSH Autosampler and an Exploris GC series system IQ/OQ

*** One cycle consists of acquiring one Full scan in positive mode and one Full scan in negative mode at resolution setting 60,000
One tSIM scan in positive mode and one tSIM scan in negative mode at resolution setting 60,000

Data acquisition system

Data system

- High-performance PC with Intel® microprocessor
- High-resolution LED color monitor
- Microsoft® Windows® 10 Enterprise (Long Term Service version) operating system
- High-speed real-time data acquisition and instrument control
- Automatic calibration of all ion transfer and analysis parameters via instrument control software

Thermo Scientific Orbitrap Exploris instrument control software

- Tune application for instrument mass and system calibrations and checks, diagnostics, and manual data acquisition
- Method Editor with a comprehensive application-specific template library, method setup supported by tooltips, and a drag-and-drop user interface to facilitate method development
- Consistent instrument control software whether using Thermo Scientific™ Xcalibur™ or Thermo Scientific™ Chromeleon™ Chromatography Data Systems (CDS) for data acquisition

Included software

Thermo Scientific Xcalibur software

- Xcalibur software is the control software for the next-generation Thermo Scientific mass spectrometer portfolio
- Accelerates familiarization and reduces training needs

Thermo Scientific™ Orbitrap™ GC-MS contaminants library

Allows fast start-up for environmental and food safety screening and quantitation applications. Contains over 800 food and environmental contaminants, including pesticides, PAHs, PCBs, dioxins, and furans. User guide included detailing how to install and make custom enhancements to library.

Optional software

Thermo Scientific Chromeleon Chromatography Data System (CDS)

Streamlined chromatographic and MS screening and quantitative workflows within an enterprise and compliance-ready single software application.

Thermo Scientific™ Compound Discoverer™ software

Streamlines small molecule unknown identification, determination of real differences between samples, and elucidation of biological pathways with an integrated suite of data analysis tools.

Thermo Scientific™ Orbitrap™ GC-MS metabolomics library

Pair with Compound Discoverer to quickly implement metabolite profiling and identification of biomarkers. Contains over 1,000 GC-Orbitrap spectra covering multiple metabolite classes. The majority of metabolite reference spectra have been derivatized with standard MSTFA and methoxyamine protocol.

Thermo Scientific™ TraceFinder™ software

Acquire and process your high-throughput screening and quantitation with built-in intelligence, driving productivity gains from data acquisition and processing to reporting.

Operation modes

Resolution settings

Ranging from 7,500 to 240,000 at m/z 200

Scan functions

Full scan

High sensitivity, high selectivity full scan for targeted and untargeted analyses.

tSIM

- Targeted SIM with Mass List Table
- With Targeted Mass Filter for ddMS²
- Isolation Width, Resolution, Polarity, Microscans set values are definable compound-dependent (w/o msx)
- Isolation Width: 0.4 u to 50 u
- Multiplexing for up to 20 compounds
- MSX ID, multiplexing groups definable
- Isolation Width set values are definable compound-dependent (w/ msx)

tMS²

- Targeted MS² with Mass List Table
- Isolation Width, HCD Collision Energy, Polarity, Microscans set values are definable compound-dependent (w/o msx)
- Isolation Width: 0.4 u to 50 u
- Multiplexing for up to 20 compounds
- Isolation Width set values can be defined compound-dependent (w/ msx)

SIM by Data-Dependent Acquisition (DDA) following a master scan (i.e., a Full MS scan or tSIM scan):

- With up to Top 100 for ddSIM
- With Targeted Mass Filter
- 'Number of Scans' (TopN) and 'Cycle Time' (Top Speed) option
- Isolation Width: 0.4 u to 50 u
- By performing a dependent scan on the most intense ion, if no target mass is found (optional)

MS² by Data-Dependent Acquisition (DDA) following a master scan (i.e., a Full MS scan or a tSIM scan):

- With up to Top 100 ddMS²
- With Targeted Mass Filter
- 'Number of Scans' (TopN) and 'Cycle Time' (Top Speed) option
- Isolation Width: 0.4 u to 50 u
- HCD Collision Energy set value is definable per compound
- By performing a dependent scan on the most intense ion, if no target mass is found (optional)

General

- Multiple experiments can be set up within one method
- One experiment can contain combinations of scans
- Collision Energy Mode' can be selected: 'Fixed' and 'Stepped'

Filters

Filters guide data-dependent (discovery and conformational) decisions on the fly and in real time. To achieve optimum results when applying application- and sample-dependent filter settings, the user is guided with appropriate application-dependent parameter settings and tool tips with tailored recommendations and detailed 'learn more' sections.

Filters can be selected as follows:

- Dynamic Exclusion
- Intensity
- Precursor Fit
- Targeted Inclusion
- Targeted Exclusion
- Apex Detection
- Precursor Selection Range

System templates

System templates provide predefined parameters in each template for users to fast load in Method Editor for data acquisition. To achieve optimum results when applying a template, the user is guided with more detailed information in help files.

System templates categories:

- Food Safety and Environmental
- POPs
- Impurity Testing
- Metabolomics
- Anti-Doping Control
- Flavor and Fragrances
- PCI Data Dependent MSMS

Installation requirements

Power

- 2 × 208–240 Vac single phase, 15 A, 50/60 Hz, with earth ground for instrument and source vacuum pump
- 208–240 Vac single phase, 15 A, 50/60 Hz, with earth ground for the data system

Gas

Helium

- High-purity helium gas supply (99.999% pure)
- Regulator output pressure adjustable from 300 to 1,000 kPa (3 to 10 bar, 45 to 145 psi)

Methane (required for CI installation)

- High-purity methane gas supply (99.999% ultra high purity)
- Regulator output pressure adjustable from 35 to 240 kPa (0.3 to 2.4 bar, 5 to 35 psi)

Nitrogen

- High-purity nitrogen gas supply (99.999% ultra-high purity)
- Regulator output pressure at 600 ±50 kPa (6.0 ±0.5 bar, 87 ±7 psi)

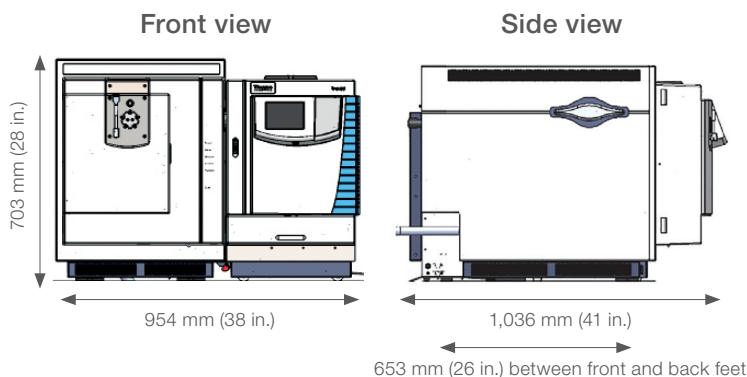

Dimensions (w, d, h)

- 954 × 1,036 × 703 mm (38 × 41 × 28 in)

Weight

- 156 kg (344 lb) including GC and one injector, without data system, vacuum rough pumps, and optional items

Environment

- System averages 3,440 W (11,730 Btu/h) output when considering air conditioning needs
- Operating environment must be 18–27 °C (64–81 °F). Relative humidity must be 20–80% with no condensation
- Designed for indoor use at an altitude of up to 3,000 m (10,000 ft) above sea level

Find out more at thermofisher.com/OrbitrapExplorisGC240