

**Thermo Scientific
KIEL IV Carbonate Device**

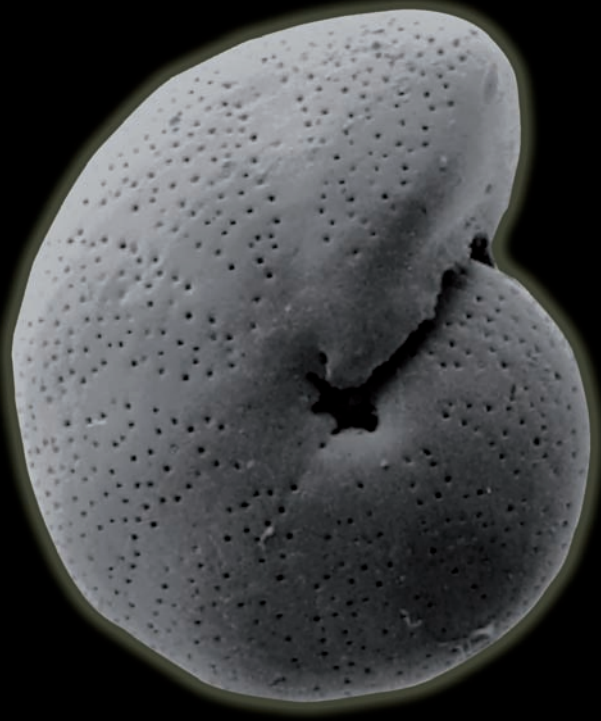

Ultimate Isotope Precision for Carbonates

Ultimate Isotope Precision

The Thermo Scientific KIEL IV Carbonate Device provides fully automated long term performance at ultimate isotope precision for more than 10,000 samples per year.

Isotope ratio analysis of carbonate samples is increasingly important in paleoclimatic reconstructions. The requirement for isotope ratio analysis of small samples of carbonate arose in studies of biogenic carbonates (e.g. foraminifera, bivalves, brachiopods, otoliths, corals). Studies of carbonates from growth zones of individual organisms and high resolution studies of microfossils from drill cores require an analytical system which can provide both high throughput and high performance in precision and accuracy over a large dynamic range of sample size.

The KIEL IV Carbonate Device coupled to either the 10-kV Thermo Scientific MAT 253 or the 3-kV DELTA V isotope ratio mass spectrometer meets the requirements of such work by providing the highest linearity at highest sensitivity, while enabling high throughput through full automation of the analytical process, from the reaction to the reporting of measurement results.

- Unique temperature controlled reaction cabinet for ultimate isotope precision of carbonates
- Two independent reaction lines with acid dosing valves for high sample throughput
- New microvolume ensuring viscous flow of CO₂ from small samples of carbonate
- "Fast bellows" strategy reducing CO₂ sample consumption during standard-to-sample pressure adjustment
- Total process control and data log file for complete insight to all preparation and measurement processes at any time
- Time slicing for realtime information of data acquisition with a resolution up to 80 data points per integration cycle

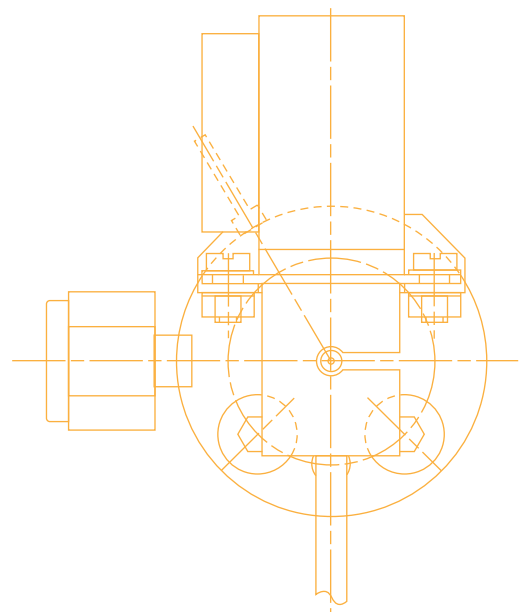
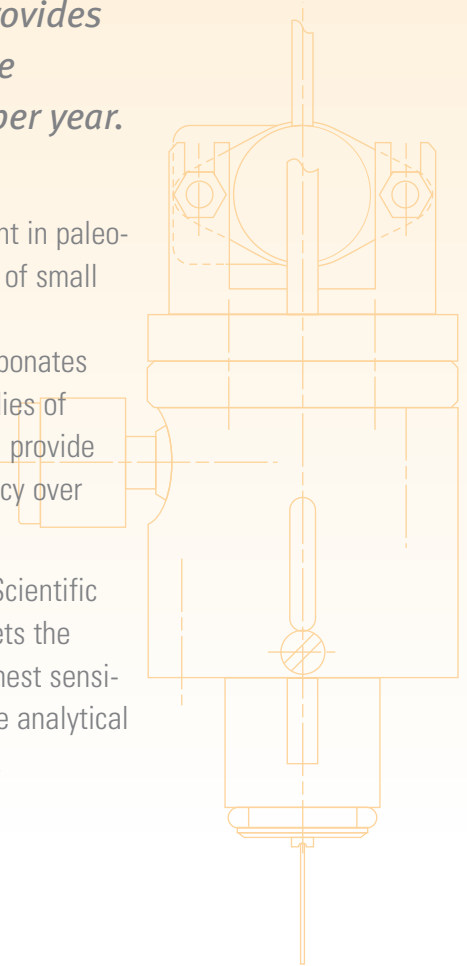

for Carbonates

Inside Views of the KIEL IV Carbonate Device

The inside views of the temperature controlled reaction cabinet (top) and the gas trapping and cleaning cabinet (bottom) show:

- ① The connection to four vacuum pumps for vial pre-evacuation
- ② The connection of reaction region and first trap
- ③ The connection to high vacuum region for first trap and microvolume evacuation

Temperature controlled reaction cabinet (front view)

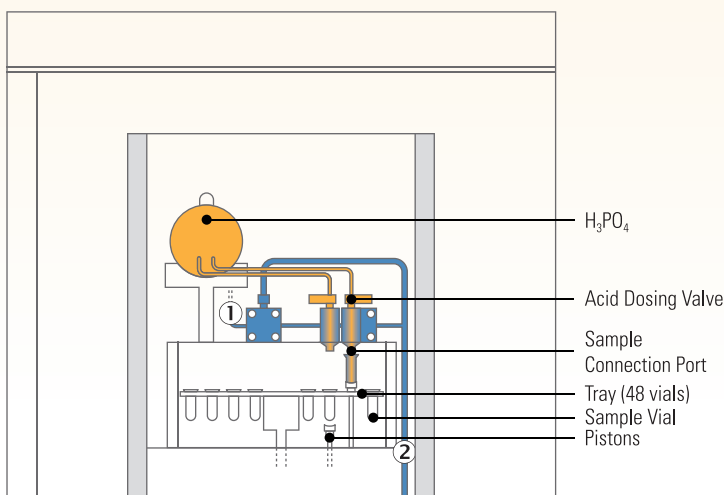

Gas trapping and cleaning cabinet (side view)

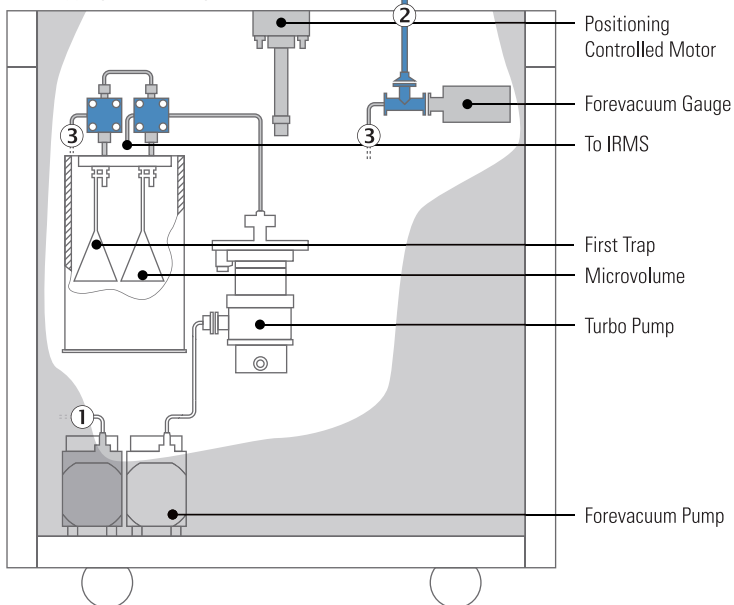

Operation of the KIEL IV Carbonate Device

The KIEL IV Carbonate Device consists of a thermostated reaction region, a trapping and gas cleaning system and a microvolume inlet system. The KIEL IV Carbonate Device uses the principle of the individual acid bath for conversion of carbonates to CO₂. Storage, transfer and chemical reaction of phosphoric acid at elevated temperatures are operated under full temperature control. Septum-free vials are used for the phosphorolysis of the carbonates. All CO₂ released is transferred and processed in an all-metal sealed cryogenic trapping system.

- Easy accessible unit for sample vial loading and pump maintenance
- Fast sample tray exchange for continuous operation
- Bake out of the complete pneumatic valve system and all stainless steel gas preparation and transfer systems
- Dual process strategy with preparation and sample measurement achieves high sample throughput
- All stainless steel construction for ultra-high vacuum
- Ultra-high vacuum closure using gold sealed pneumatic valves
- 1/8" to 1/4" connections assuring highest pumping efficiency
- Fibreline optics guarantee ground-loop-free operation

CO₂ Sample Gas Preparation and Transfer

The reaction of carbonates with phosphoric acid produces CO₂ and H₂O plus non-condensable gases from impurities in the sample. The cryogenic trapping system consists of a temperature controlled first trap with associated valves, ultra-high vacuum system, pressure gauge and a microvolume.

- Carbonate samples, phosphoric acid storage, acid transfer and chemical reaction under identical conditions in a precision temperature controlled oven (+/- 0.1 °C)
- Storage of phosphoric acid in a 500 ml reservoir in the thermostated environment of the KIEL IV to keep the acid under absolutely dry conditions and for a long measurement period
- Additional drying storage of prepared sample vials in the same temperature controlled environment as sample analysis (+/- 0.1 °C)
- Full temperature controlled and CO₂ memory-free individual acid bath reaction
- System uses 105% dry phosphoric acid
- Septum-free and reusable borosilicate vials
- Fully observable vial content at any time
- High sample throughput for high precision carbonate analysis (46 samples a day)
- Drop test under vacuum and reaction conditions before chemical reaction
- Control and monitoring of ultra-high vacuum in the complete reaction and preparation system
- Automated high vacuum system check before each sample reaction from the sample vial to the CO₂ freezing trap

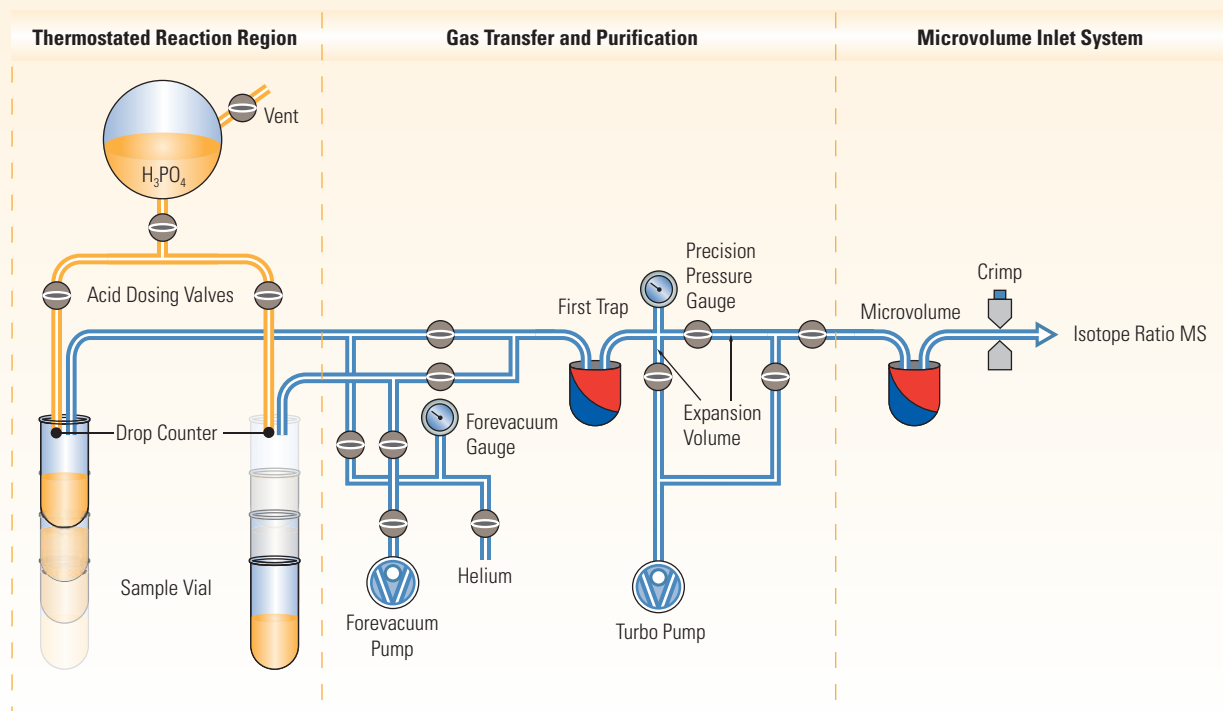

Schematic of the KIEL IV Carbonate Device

In the first step, CO_2 and H_2O are trapped into the first automated liquid nitrogen trap at $-190\text{ }^\circ\text{C}$ while any non-condensable gases are removed. The CO_2 is then released at $-90\text{ }^\circ\text{C}$ for transfer into the microvolume, while the water is completely retained in the first trap. Based on the pressure of the released CO_2 the Isodat software suite defines the portion of CO_2 being transferred into the microvolume. This software process assures the optimal sample gas pressure in the Isotope Ratio MS. In parallel the reference gas below in the dual inlet is pre-adjusted to the expected inlet pressure.

- Low liquid nitrogen consumption (0.5L/sample) by automated liquid nitrogen refill into a low volume Dewar with a new level detector mechanism
- High throughput of carbonate in routine operation (> 10,000 analyses per year) with the only consumable being LN_2
- Redesigned trapping and gas cleaning system with new transfer line, LN_2 level indicator and trap temperature control
- Water and temperature resistant compact cartridge design which includes both the temperature sensor and heating cartridge
- Perfect temperature regulation through direct positioning of the cartridge to the spot of sample freezing
- CO_2 sample yield determination with a precision pressure gauge at the first trap
- Complete bake-out of the system

Sample Analysis and Referencing

The microvolume is heated to $+30\text{ }^\circ\text{C}$ releasing the CO_2 via a dedicated stainless steel capillary to the changeover valve and into the IRMS for $\delta^{13}\text{C}$ and $\delta^{18}\text{O}$ analysis. In parallel, water is removed from the gas cleaning and trapping system by baking the first trap and evacuating all valves and gas lines.

- New small microvolume inlet systems for KIEL IV and Dual Inlet
- New microvolume design for smallest amount of samples with highest precision (e.g. in the range of $6\text{ }\mu\text{g}$ to $130\text{ }\mu\text{g}$)*
- Regulated CO_2 transfer to the KIEL IV microvolume to achieve the desired inlet pressure for measurement
- Same CO_2 sample gas flow from the chemical reaction to the IRMS guarantees the principle of identical treatment of samples
- Fast bellow reference gas pressure pre-adjustment using the CO_2 sample yield determination
- Highest precision isotope measurements with a dedicated stainless steel inlet capillary

*See Thermo Scientific Application Note AN30176

An overall external precision of $0.04\text{ }^\circ\text{‰}$ for $\delta^{13}\text{C}$ and $0.08\text{ }^\circ\text{‰}$ for $\delta^{18}\text{O}$ using the Thermo Scientific MAT 253 is reached for samples greater than $20\text{ }\mu\text{g}$. In routine operation, laboratories have shown throughputs up to 15,000 analyses per year with the only consumable being LN_2 .

for Carbonates

The KIEL IV Carbonate Device uses the principle of individual acid baths. Storage, transfer and chemical reaction of phosphoric acid at elevated temperatures operate under full temperature control. CO₂ evolves in septum-free vials and diffuses under medium vacuum pressure into a cryogenic trapping system. Water and non-condensable gases evolved during phosphorolysis are removed from the CO₂ gas phase under high vacuum in the first trap. Prior to transfer into the microvolume, the CO₂ pressure is monitored and, if required, the CO₂ sample size can be reduced by expansion into a defined volume. In the microvolume, the dry CO₂ is prepared for analysis in a dual microvolume inlet system which features a new design of the microvolume on the sample side.

An overall precision of 0.04 ‰ for δ¹³C and 0.08 ‰ δ¹⁸O is reached for samples greater than 20 µg. In routine operation, laboratories have shown throughputs up to 15,000 analyses per year with the only consumable being LN₂. The savings achieved by eliminating the requirement for new septa every 1,000 samples is considerable.

Analytical Performance

With a sample size of > 20 µg for MAT 253 or > 40 µg for DELTA V and MAT 253, the following performance for one full autosampler run (46 samples) will be achieved.

EXTERNAL PRECISION 1 σ

| | |
|--|--------|
| Carbon (¹³ C/ ¹² C) | 0.04 ‰ |
| Oxygen (¹⁸ O/ ¹⁶ O) | 0.08 ‰ |

For more details on analytical performance, please contact your local sales representative.

Fully Automated Long Term Isotope Precision

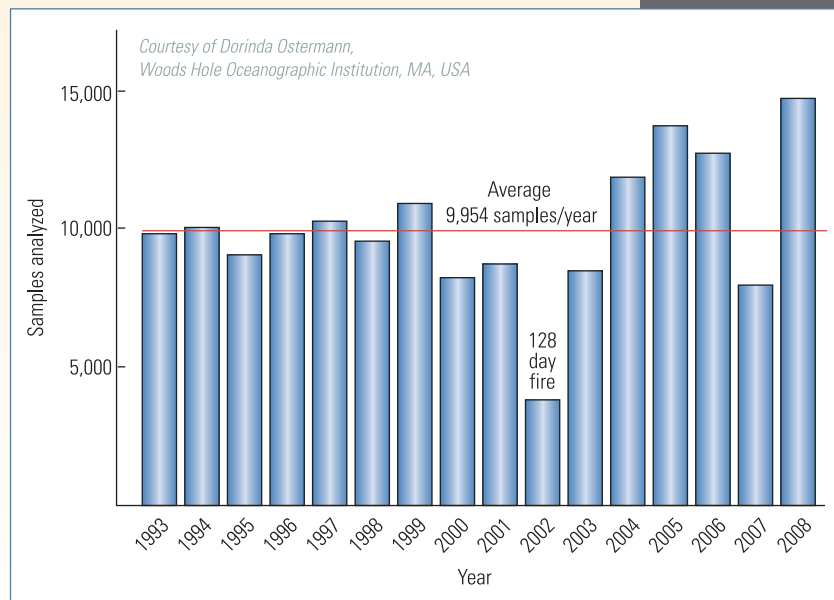

Installation Requirements

THERMO SCIENTIFIC KIEL IV CARBONATE DEVICE

| | |
|-----------------|---|
| Instrumentation | The KIEL IV Carbonate Device connects to Thermo Scientific MAT 253 and DELTA V stable isotope ratio MS equipped with a dual inlet system. |
| Liquid Nitrogen | 0.5 L/sample Optional: 90 L Dewar for long term operation |
| Compressed Air | 350 to 500 kPa (50 to 75 psi) |
| Gases | Helium or argon, about 15 mL per sample (for pressurized release of sample containers from reaction position) |
| Power | 50/60 Hz |
| Voltage | 230V, single phase, 10A = 2,200 Watt |
| Environment | Ambient temperature between 18 °C and 28 °C, with a relative humidity between 20 and 70% |
| Dimensions | 90 cm (width) x 90 cm (depth) x 190 cm (height) |
| Weight | approx. 100 kg (220 lbs.) |

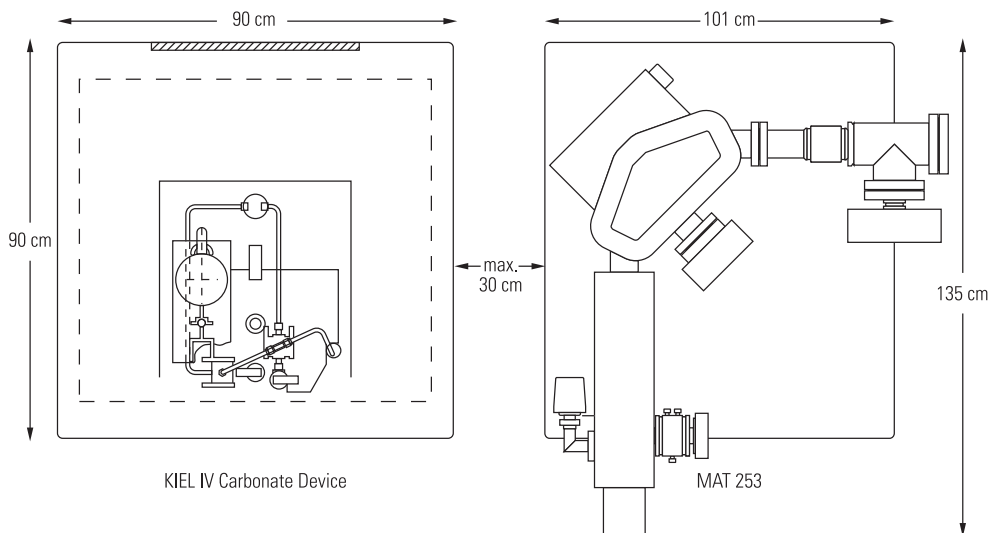

Laboratory Solutions Backed by Worldwide Service and Support

Tap our expertise throughout the life of your instrument. Thermo Scientific Services extends its support throughout our worldwide network of highly trained and certified engineers who are experts in laboratory technologies and applications. Put our team of experts to work for you in a range of disciplines – from system installation, training and technical support, to complete asset management and regulatory compliance consulting. Improve your productivity and lower the cost of instrument ownership through our product support services. Maximize uptime while eliminating the uncontrollable cost of unplanned maintenance and repairs. When it's time to enhance your system, we also offer certified parts and a range of accessories and consumables suited to your application.

To learn more about our products and comprehensive service offerings, visit us at www.thermo.com.

In addition to these offices, Thermo Fisher Scientific maintains a network of representative organizations throughout the world.

Africa-Other

+27 11 570 1840 • analyze.sa@thermo.com

Australia

+61 2 8844 9500 • analyze.au@thermo.com

Austria

+43 1 333 50 34 0 • analyze.at@thermo.com

Belgium

+32 2 482 30 30 • analyze.be@thermo.com

Canada

+1 800 530 8447 • analyze.ca@thermo.com

China

+86 10 8419 3588 • analyze.cn@thermo.com

Denmark

+45 70 23 62 60 • analyze.dk@thermo.com

Europe - Other

+43 1 333 50 34 0 • analyze.emea@thermo.com

Finland / Norway / Sweden

+46 8 556 468 00 • analyze.se@thermo.com

France

+33 1 60 92 48 00 • analyze.fr@thermo.com

Germany

+49 6103 408 1014 • analyze.de@thermo.com

India

+91 22 6742 9434 • analyze.in@thermo.com

Italy

+39 02 950 591 • analyze.it@thermo.com

Japan

+81 45 453 9100 • analyze.jp@thermo.com

Latin America

+1 608 276 5659 • analyze.la@thermo.com

Middle East

+43 1 333 50 34 0 • analyze.emea@thermo.com

Netherlands

+31 76 579 55 55 • analyze.nl@thermo.com

South Africa

+27 11 570 1840 • analyze.sa@thermo.com

Spain

+34 914 845 965 • analyze.es@thermo.com

Switzerland

+41 61 716 77 00 • analyze.ch@thermo.com

UK

+44 1442 233555 • analyze.uk@thermo.com

USA

+1 800 532 4752 • analyze.us@thermo.com

www.thermo.com

Thermo Fisher Scientific (Bremen) GmbH
Management System Registered to ISO 9001:2008

©2009 Thermo Fisher Scientific Inc. All rights reserved.
All trademarks are the property of Thermo Fisher Scientific Inc. and its subsidiaries.

Specifications, terms and pricing are subject to change.
Not all products are available in all countries. Please consult your local sales representative for details.

BR30178_E 10/09C

Thermo
SCIENTIFIC