



**Technical Data Sheet**  
**Revco Ultra-Low Temperature Upright Freezer**  
 MODEL RELEASE - 65  
 Thermo Fisher Scientific, Asheville, North Carolina

Specifications	Model Number
	Thermo Scientific Revco UxF30086A WC
Application, Rating and Electrical Data	
Application	Storage of General (non-flammable) Laboratory Materials
Storage Volume	421 liters / 14.9 cu. ft., 300 Standard 2" Boxes
Temperature Rating	-50°C to -86°C
Electrical Power	120V, 60 Hz, 1 Phase
Instrument Rated Current	16.0 AMP
Building Supply Rating	20.0A dedicated grounded circuit. Protected by circuit breaker rated for inductive loads
Power Plug/Power Cord Length	NEMA 5-20P / IEC Cords, 3.048 Meters (10 Feet)
Agency Listings	UL, cUL
Indoor/Outdoor Usage	Indoor Use Only
Application Environment	Non-Corrosive, Non-Flammable, Non-Explosive, Good Air Ventilation, 15° C - 32° C (59° F - 90° F)
Cooling Water Condition	Inlet Temp: (12C - 25C) / (54F - 77F); Min Flow Rate: 3.8 LPM / 1 GPM; Max Pressure: 6.2 bar / 90 psia
Refrigeration Configuration	
Refrigeration System	Industrial-Rated Two Stage Cascade System
Compressor / Number	Hermetic Compressor for Low Temperature Application / 2
Compressor Capacity*	1200 W
Condenser Type/Number	Brazed Plate Heat Exchanger With Water Cooled / 1
Expansion Device	Capillary Tube
Evaporator Type	Cold Wall With Enhanced Heat Transfer Treatment
Defrost Method	Manual Defrost
Refrigerant Charge/Flammability	R404A in 1st Stage / R508B+R290 Mix in 2nd Stage / Non-Flammable
Controller/Electrical System Configuration and Features	
Controller Level	Top
Power Switch	On-Off with Circuit Breaker
Controller Type	Microprocessor Control with Touch Screen Input and Display. Includes USB System Data Retrieval
Setpoint Security	Yes
Compressor Safe Guard	High Pressure Cutout Switch/High Temp Cutout Switch/Current protection/Logic protection
Control Sensor	Single RTD (1000 ohm Platinum RTD)
Remote Alarm Terminals	RS485/4-20mA output
Adjustable Warm/Cold Alarms	Fully Adjustable
Auto-Voltage Safeguard	Buck/Boost System
Dimensions and Construction	
Interior Dimensions (H x D x W)	1300 H x 686 D x 452 W mm (51.2 H x 27 D x 17.8 W in.)
Exterior Dimensions (H x D x W)	1981 H x 955 D x 688 W mm (78 H x 37.6 D x 27.1 W in.)
Shipping Dimensions	2111 H x 1086 D x 864 W mm (83.12 H x 42.75 D x 34 W in)
Insulation	High R-value Vacuum Insulation Panels and High Density Water-Blown Polyurethane Foam
Door Seal	Silicone-Based High Performance Seal Gasket with Electrical Door Perimeter Heater
Shelves / Capacity	4 Stainless Steel Shelves Adjustable In 25mm (1in) Increments. Max. Cap. per Shelf: 56.8 kg (125 lbs.)
All-Direction Casters	Standard with Locks
Shipping Weight	Approximately 303 kg / 667 lbs.
Other Options	LN2 or CO2 Back Up System, HID Controlled Access, SMS Text, Chart Recorder, 4 or 5 Inner Doors

**Typical Performance Characteristics in 20 ° C Ambient**

PD & WU at 20C, 300V Water-Cooled ULT, 18870-A-Q

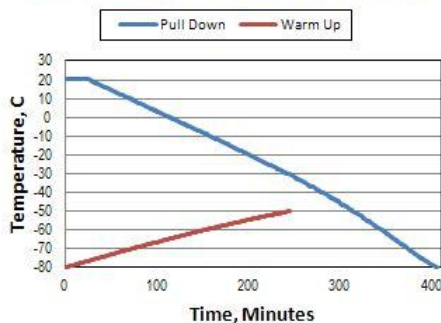

-80C Cycle at 20C, 300V Water-Cooled ULT, 18870-A-Q

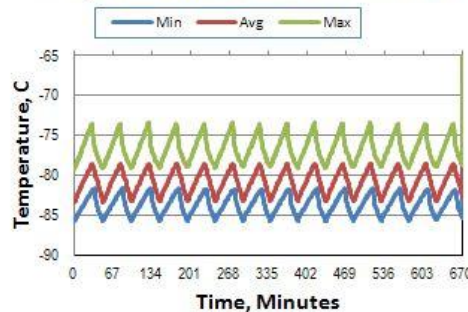

Test Unit Number:	18870-A-Q
Avg Cabinet Temp at -80 C Cycle (C):	-80.9
PV from Setpoint, High Performance (C):	+ 6.6 / - 5.8
PV from Setpoint, Energy Saving (C):	+ 11.4 / - 4.4
Uniformity at -80C, High Performance (C):	7.1
Stability at -80C, High Performance (C):	5.4
1-min Door Open Recovery to -75C (min)	11
Duty Cycle at -80C, High Performance (%):	43.6%
Cycle (on/off) rate at -80C, High Performance (min):	21 / 27
Energy Consumption, High Performance (kWh/day):	13.2
Heat rejection at -80C, High Performance (Btu/hr):	658
Energy Consumption, Energy Saving (kWh/day):	12.4
Heat rejection at -80C, Energy Saving (Btu/hr):	617
Pulldown Time to -80C (hrs):	6.8
Warmup Time (-80 to -50 C) (minutes):	245
Water Supply Inlet Temperature (C)	18

- 1) Performance is nominal and individual units may vary.
- 2) Freezer performance will differ due to product amount, product size and operating conditions.
- 3) Continuous product enhancements may, without notice, result in amendments or omissions to this specification. Thermo Scientific cannot accept responsibility for damage, injury, loss or expenses resulting from misapplication of the information herein.

\* Manufacturer measured compressor capacity taken at standard -23°C/49°C (Evap/Cond) condition.

© 2012 Thermo Scientific Inc. All trademarks are the property of Thermo Scientific Inc. and its subsidiaries. Specifications, terms and pricing are subject to change. Not all products are available in all countries. Please consult your local sales representative for details.

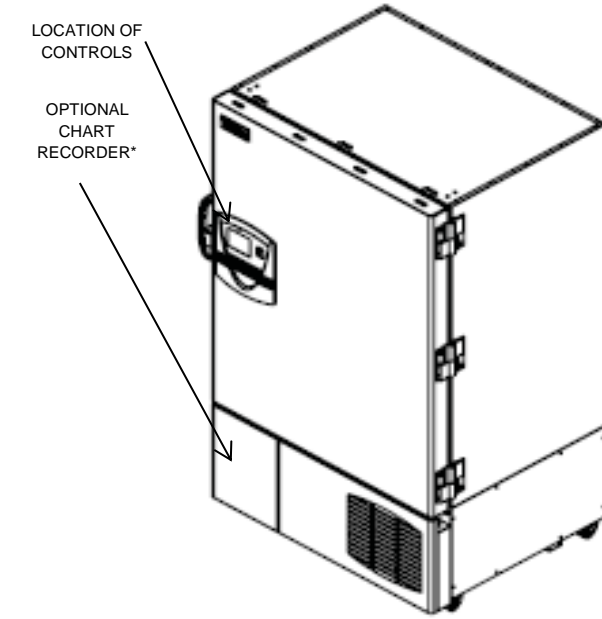
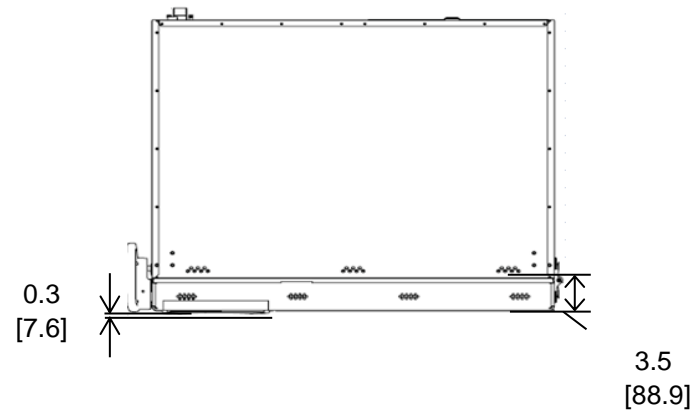
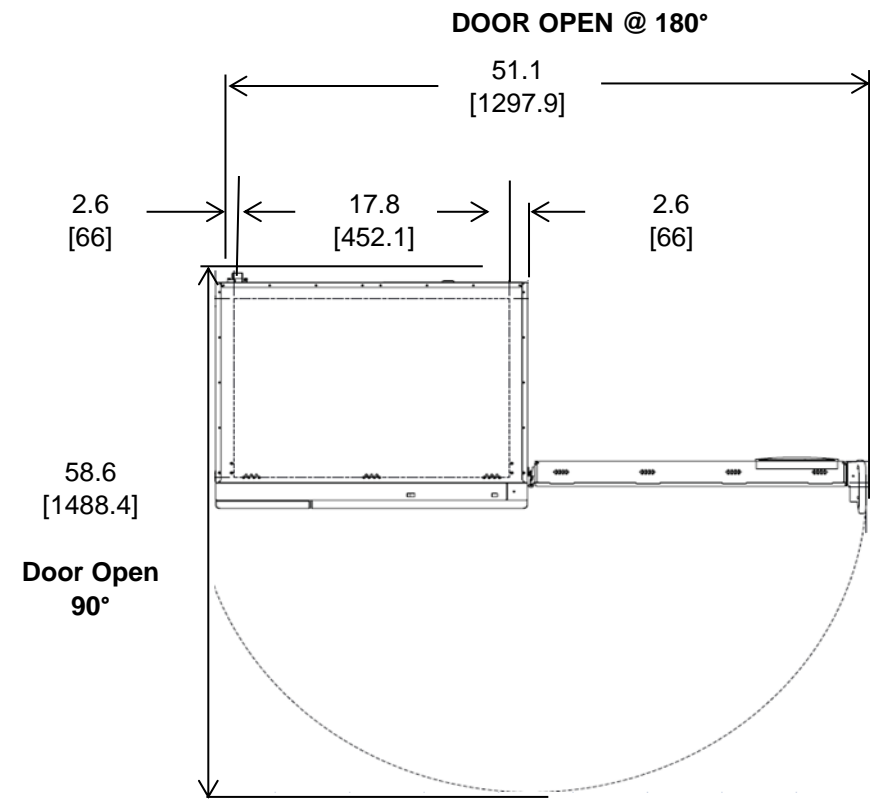

\*Chart recorder/Back up systems are stand alone on 300 models.

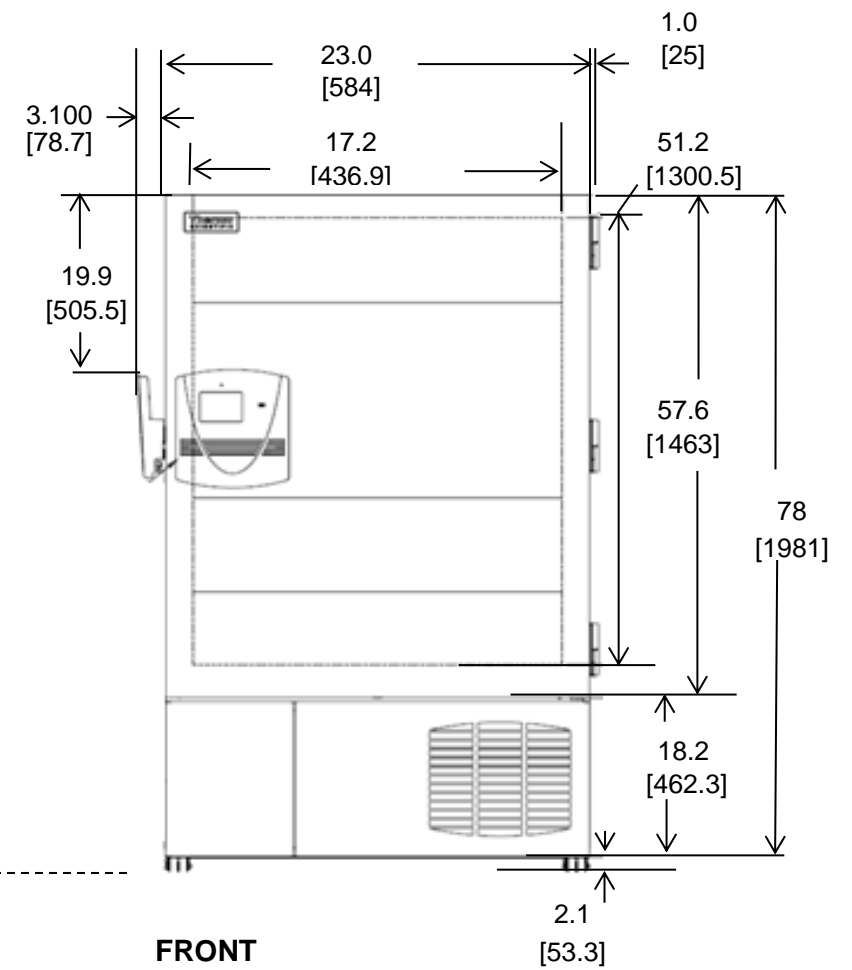
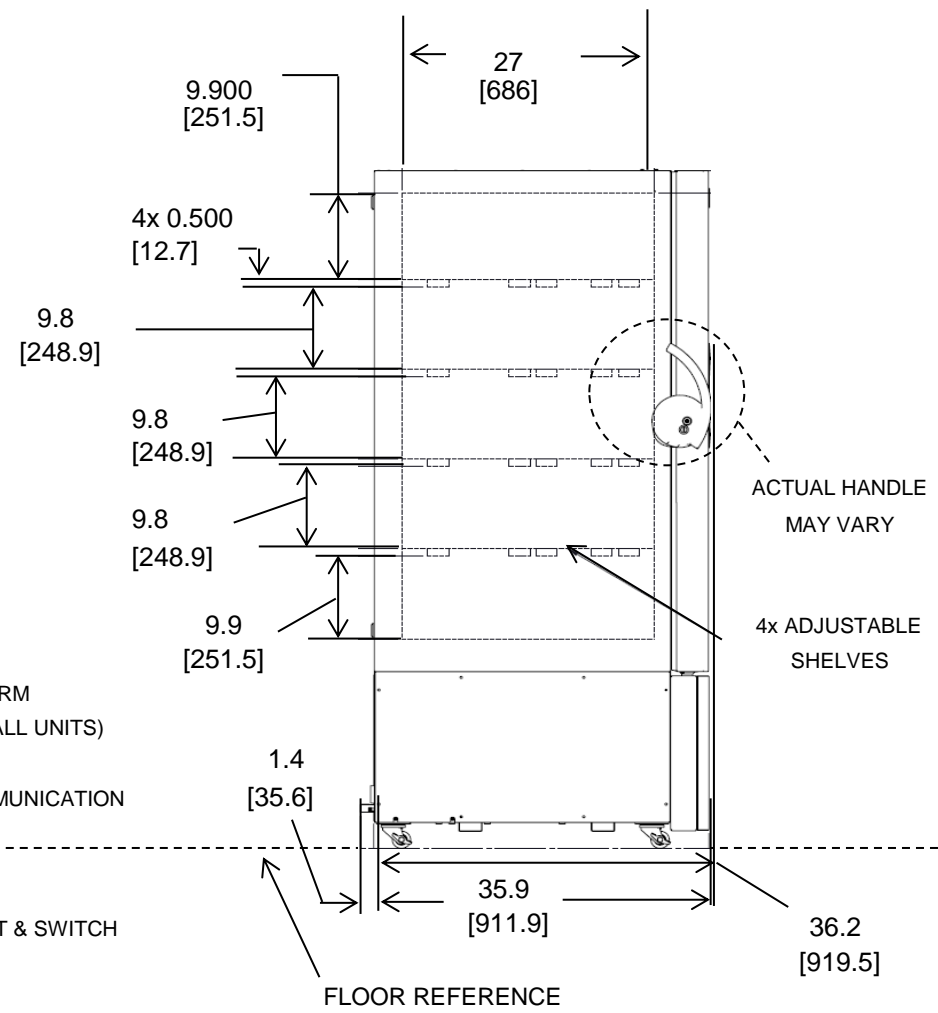
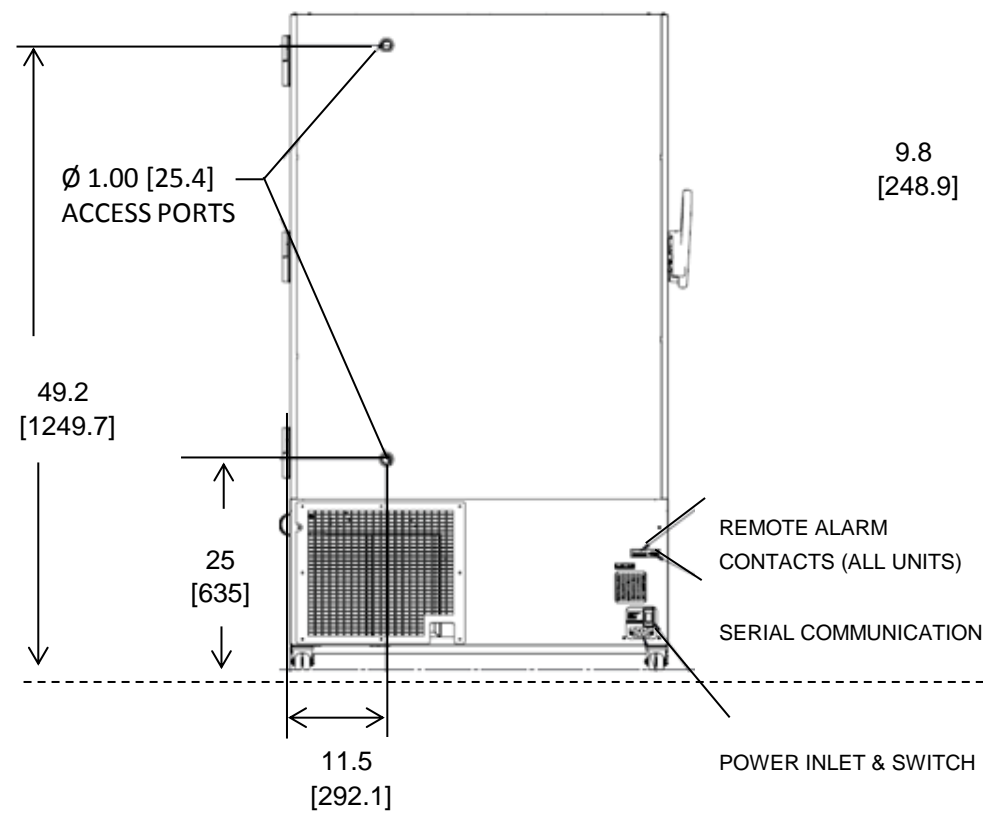

**BACK**

**NOTE: DUAL DIMENSION IS INCH OVER METRIC**

DO NOT USE FOR ENGINEERING PURPOSES. SUBJECT TO CHANGE WITHOUT NOTICE.

**Thermo**  
SCIENTIFIC

**15 cuft Upright Freezer**  
5 Inner Doors  
Single Outer Door  
Top Mount Controls