

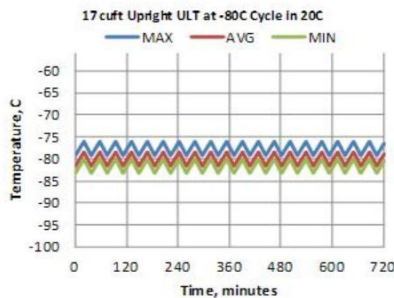

Technical Data Sheet
Forma Ultra-Low Temperature Upright Freezer
 MODEL RELEASE - 21
 Thermo Fisher Scientific, Asheville, North Carolina

Specifications	Model Number
	905
	Application, Rating and Electrical Data
Application	Storage of General (non-flammable) Laboratory Materials
Storage Volume	489.9 Liters / 17.3 Cubic Feet
Temperature Rating	-50°C to -86°C
Electrical Power	230V 50 Hz, 1 Phase
Instrument Rated Current	12.0 AMP
Building Supply Rating	15.0A dedicated grounded circuit. Protected by circuit breaker rated for inductive loads
Power Plug/Power Cord Length	Country Dependant plug / IEC Cords, 3.048 Meters (10 Feet)
Agency Listings	CE, FDA
Indoor/Outdoor Usage	Indoor Use Only
Application Environment	Non-Corrosive, Non-Flammable, Non-Explosive, Good Air Ventilation, 15° C - 32° C (59° F - 90° F)
Refrigeration Configuration	
Refrigeration System	Industrial-Rated Two Stage Cascade System
Compressor / Number	Hermetic Compressor for Low Temperature Application / 2
Compressor Capacity*	980 W
Condenser Type/Number	Enhanced Finned-Tube and Forced-Air Cooled / 1
Expansion Device	Capillary Tube
Evaporator Type	Cold Wall With Enhanced Heat Transfer Treatment
Defrost Method	Manual Defrost
Refrigerant Charge/Flammability	R404A in 1st Stage / R508B+R290 Mix in 2nd Stage / Non-Flammable
Controller/Electrical System Configuration and Features	
Controller Level	Top
Power Switch	On-Off with Circuit Breaker
Controller Type	Microprocess Control
Setpoint Security	NO
Compressor Safe Guard	High Pressure Cutout Switch/High Temp Cutout Switch/Current protection/Logic protection
Control Sensor	Single RTD (1000 ohm Platinum RTD)
Remote Alarm Terminals	RS485, 4-20mA, Dry Contacts
Adjustable Warm/Cold Alarms	Fully Adjustable
Auto-Voltage Safeguard	Buck/Boost System
Dimensions and Construction	
Interior Dimensions (H x D x W)	1308 H x 645 D x 586 W mm (51.5 H x 25.4 D x 23.1 W in.)
Exterior Dimensions (H x D x W)	1978 H x 988 D x 912 W mm (77.9 H x 38.9 D x 35.9 W in.)
Shipping Dimensions	2096 H x 1156 D x 1062 W mm (82.5 H x 45.5 D x 41.8 W in)
Insulation	High Density Polyurethane Foam, R-30 (ft ² ·°F·hr/Btu)
Door Seal	Silicone-Based High Performance Seal Gasket
Shelves / Capacity	3 Stainless Steel Shelves Adjustable In 25 mm (1 in) Increment; Maximum Capacity/Shelf: 45.4 kg (100 Lbs.)
All-Direction Casters	Standard with Locks
Unit Weight	Approximately 338 kg / 745 lbs.
Other Options	Electronic Recorder and CO2 or LN2 Back-Up System or Datalogger

Typical Performance Characteristics in 20 ° C Ambient

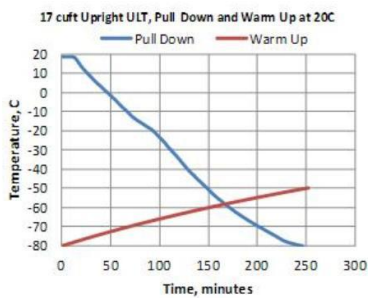

Test Unit Series Number or MSO Number:	19118-BA-T10
Cabinet Load:	Unloaded
Average Cabinet Temp at -80C Cycle (C):	-79.9
Peak Variation from Setpoint (C):	+4/ -3.3
Uniformity (C):	4
Stability (C):	3
1-min Door Opening Recovery to -75C (min):	21
Duty Cycle at -80C (%):	47
Cycle (on/off) rate at -80C (min):	17 / 20
Energy Consumption (kw-hr/day):	12.5
Heat Rejection Rate (btu/hr):	1783
Pull Down Time (to -80C) (min):	246
Warm Up Time (-80C to -50C) (min):	252

- 1) Performance is nominal and individual units may vary.
- 2) Freezer performance will differ due to product amount, product size and operating conditions.
- 3) Continuous product enhancements may, without notice, result in amendments or omissions to this specification. Thermo Scientific cannot accept responsibility for damage, injury, loss or expenses resulting from misapplication of the information herein.

* Manufacturer measured compressor capacity taken at standard -23°C/49°C (Evap/Cond) condition.

© 2012 Thermo Scientific Inc. All trademarks are the property of Thermo Scientific Inc. and its subsidiaries. Specifications, terms and pricing are subject to change. Not all products are available in all countries. Please consult your local sales representative for details.

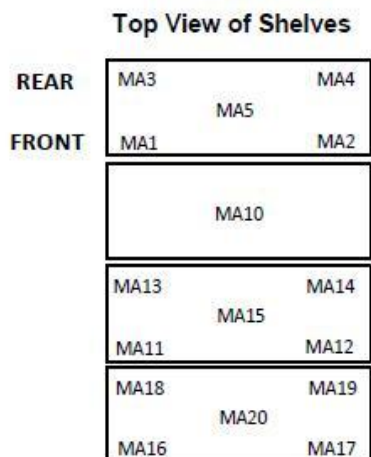

Cabinet Average: -79.9 C
Probe Average: -79.7 C
Peak Variation: +4 C / -3.3 C

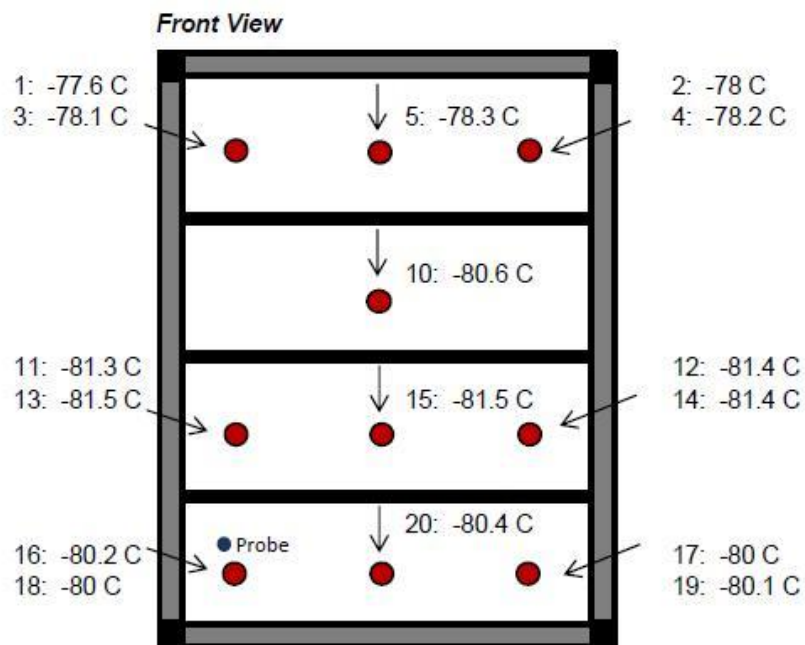

19118-BA-T10

°C	MA1	MA2	MA3	MA4	MA5	MA10	MA11	MA12	MA13
Avg	-77.6	-78.0	-78.1	-78.2	-78.3	-80.6	-81.3	-81.4	-81.5
Max	-76.1	-76.6	-76.6	-76.5	-76.9	-79.3	-79.9	-79.8	-79.9
Min	-78.9	-79.3	-79.4	-79.6	-79.6	-81.8	-83.0	-83.1	-83.3

	MA14	MA15	MA16	MA17	MA18	MA19	MA20
Avg	-81.4	-81.5	-80.2	-80.0	-80.0	-80.1	-80.4
Max	-79.9	-79.8	-78.9	-78.5	-78.5	-78.8	-79.0
Min	-83.2	-83.2	-81.7	-81.8	-81.6	-81.9	-82.2

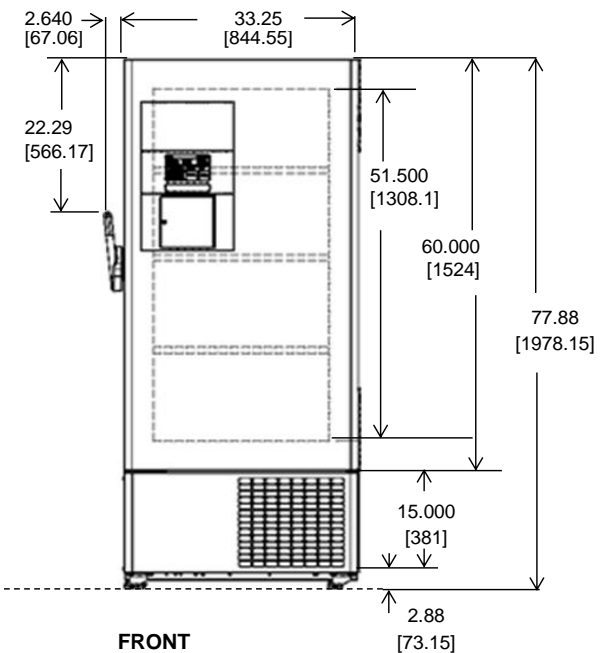
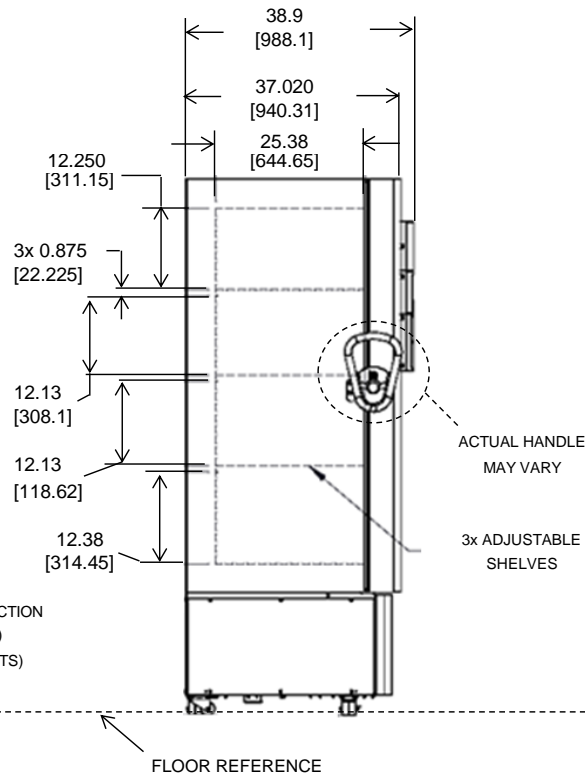
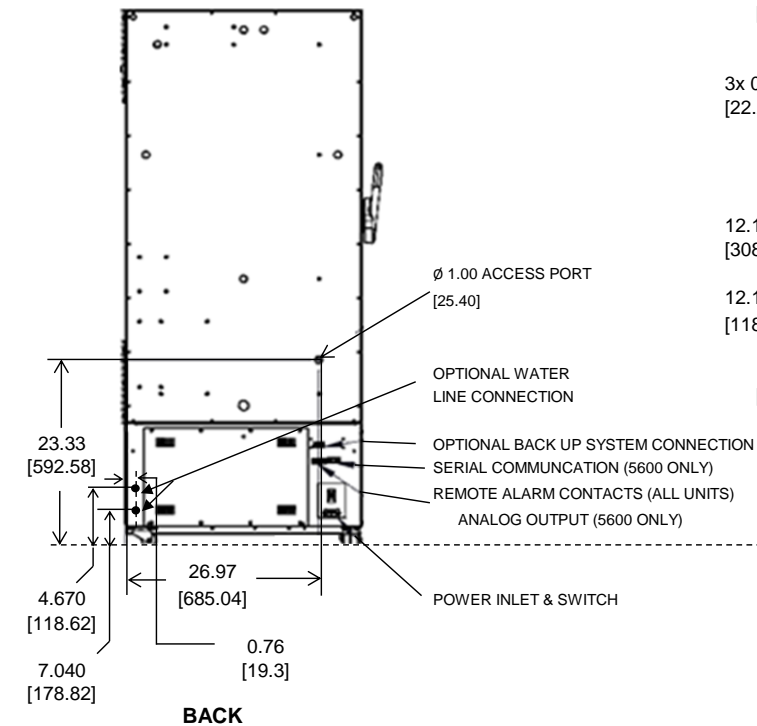
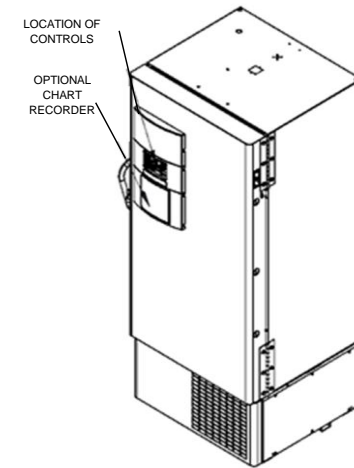
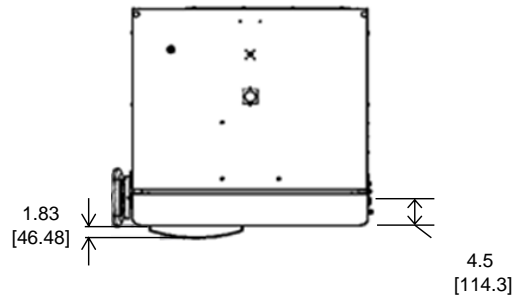
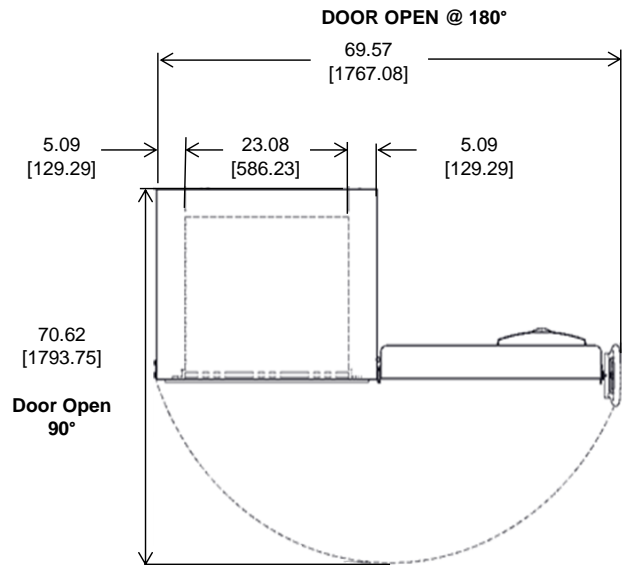

NOTE: DUAL DIMENSION IS INCH OVER METRIC

DO NOT USE FOR ENGINEERING PURPOSES. SUBJECT TO CHANGE WITHOUT NOTICE.

Thermo
SCIENTIFIC

17 cuft Upright Freezer
4 Inner Doors
Single Outer Door
Top Mount Controls