



Technical Data Sheet
Forma Ultra-Low Temperature Upright Freezer
 MODEL RELEASE - 65
 Thermo Fisher Scientific, Asheville, North Carolina

Specifications	Model Number
	Thermo Scientific Forma 88600A
	Application, Rating and Electrical Data
Application	Storage of General (non-flammable) Laboratory Materials
Storage Volume	815 liters / 28.8 cu. ft., 600 Standard 2" Boxes
Temperature Rating	-50°C to -86°C
Electrical Power	120V, 60 Hz, 1 Phase
Instrument Rated Current	16.0 AMP
Building Supply Rating	20.0A dedicated grounded circuit. Protected by circuit breaker rated for inductive loads
Power Plug/Power Cord Length	NEMA 5-20P / IEC Cords, 3.048 Meters (10 Feet)
Agency Listings	UL, cUL
Indoor/Outdoor Usage	Indoor Use Only
Application Environment	Non-Corrosive, Non-Flammable, Non-Explosive, Good Air Ventilation, 15° C - 32° C (59° F - 90° F)
Refrigeration Configuration	
Refrigeration System	Industrial-Rated Two Stage Cascade System
Compressor / Number	Hermetic Compressor for Low Temperature Application / 2
Compressor Capacity*	1200 W
Condenser Type/Number	Enhanced Finned-Tube and Forced-Air Cooled / 1
Expansion Device	Capillary Tube
Evaporator Type	Cold Wall With Enhanced Heat Transfer Treatment
Defrost Method	Manual Defrost
Refrigerant Charge/Flammability	R404A in 1st Stage / R508B+R290 Mix in 2nd Stage / Non-Flammable
Controller/Electrical System Configuration and Features	
Controller Level	Top
Power Switch	On-Off with Circuit Breaker
Controller Type	Microprocessor Control with Touch Screen Input and Display. Includes USB System Data Retrieval
Setpoint Security	Yes
Compressor Safe Guard	High Pressure Cutout Switch/High Temp Cutout Switch/Current protection/Logic protection
Control Sensor	Single RTD (1000 ohm Platinum RTD)
Remote Alarm Terminals	RS485/4-20mA output
Adjustable Warm/Cold Alarms	Fully Adjustable
Auto-Voltage Safeguard	Buck/Boost System
Dimensions and Construction	
Interior Dimensions (H x D x W)	1300 H x 686 D x 874 W mm (51.2 H x 27 D x 34.4 W in.)
Exterior Dimensions (H x D x W)	1981 H x 960 D x 1102 W mm (78 H x 37.8 D x 43.4 W in.)
Shipping Dimensions	2111 H x 1086 D x 1206 W mm (83.12 H x 42.75 D x 47.48 W in)
Insulation	High R-value Vacuum Insulation Panels and High Density Water-Blown Polyurethane Foam
Door Seal	Silicone-Based High Performance Seal Gasket with Electrical Door Perimeter Heater
Shelves / Capacity	3 Stainless Steel Shelves Adjustable In 25mm (1in) Increments. Max. Cap. per Shelf: 110 kg (245 lbs.)
All-Direction Casters	Standard with Locks
Shipping Weight	Approximately 388 kg / 854 lbs.
Other Options	LN2 or CO2 Back Up System, HID Controlled Access, SMS Text, Chart Recorder, 4 or 5 Inner Doors

Typical Performance Characteristics in 25 ° C Ambient

Performance Data Summary (Typical Average Values)

Avg. Cabinet Temp. at -80C Setpoint, High Performance (C):	-79.5
Peak Variation From -80C Setpoint, High Performance (C):	+4.9 / -2.9
Peak Variation From -80C Setpoint, Energy Saving (C):	+9.6 / -0.8
Stability, -80C Setpoint, High Performance (C):	2.5
Uniformity, -80C Setpoint, High Performance (C):	5.2
1 Min. Door Open Recovery to -75C Avg. Cabinet Temp. (min):	33
Cycle Rate, -80C Setpoint, High Performance (on/off, min/min):	19/12
Duty Cycle, -80C Setpoint, High Performance (%):	62
Energy Consumption, -80C Setpoint, High Performance (kWh/day):	21.3
Heat Rejection, -80C Setpoint, High Performance (BTU/hr):	3028
Energy Consumption, -80C Setpoint, Energy Saving (kWh/day):	17.7
Heat Rejection, -80C Setpoint, Energy Saving (BTU/hr):	2516
Pulldown Time to -80C Average Cabinet Temp. (hours)	7.9
Warmup Time, From Average Cabinet Temp. of -80C to -50C (min):	257

1) Performance is nominal and individual units may vary.
 2) Freezer performance will differ due to product amount, product size and operating conditions.
 3) Continuous product enhancements may, without notice, result in amendments or omissions to this specification. Thermo Scientific cannot accept responsibility for damage, injury, loss or expenses resulting from misapplication of the information herein.

* Manufacturer measured compressor capacity taken at standard -23°C/49°C (Evap/Cond) condition.
 © 2012 Thermo Scientific Inc. All trademarks are the property of Thermo Scientific Inc. and its subsidiaries. Specifications, terms and pricing are subject to change. Not all products are available in all countries. Please consult your local sales representative for details.

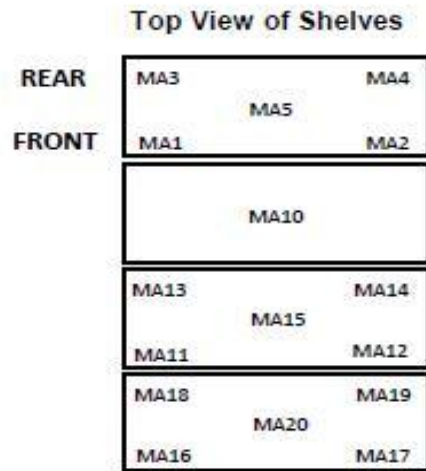

Cabinet Average: -79.6 C
Probe Average: -81.3 C
Peak Variation: +4.9 C / 3 C

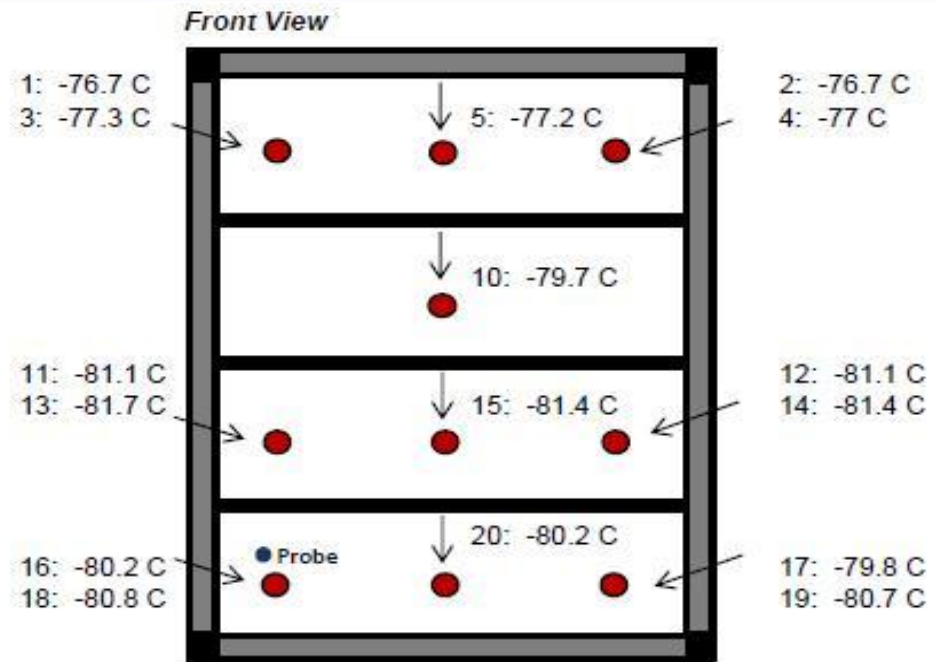

18768-H-X

°C	MA1	MA2	MA3	MA4	MA5	MA10	MA11	MA12	MA13
Avg	-76.7	-76.7	-77.3	-77.0	-77.2	-79.7	-81.1	-81.1	-81.7
Max	-75.2	-75.1	-75.6	-75.5	-75.7	-78.1	-79.8	-79.8	-80.3
Min	-77.8	-77.8	-78.6	-78.2	-78.3	-80.9	-82.3	-82.4	-83.0

	MA14	MA15	MA16	MA17	MA18	MA19	MA20
Avg	-81.4	-81.4	-80.2	-79.8	-80.8	-80.7	-80.2
Max	-79.9	-80.1	-79.1	-78.5	-79.5	-79.3	-78.9
Min	-82.9	-82.8	-82.0	-81.7	-82.8	-82.6	-82.0

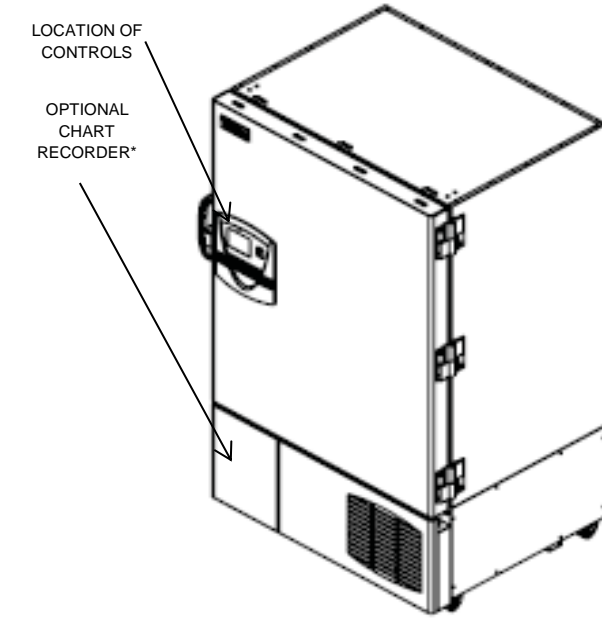
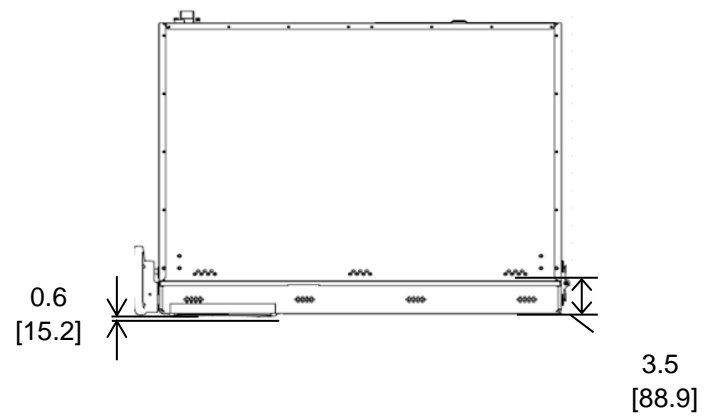
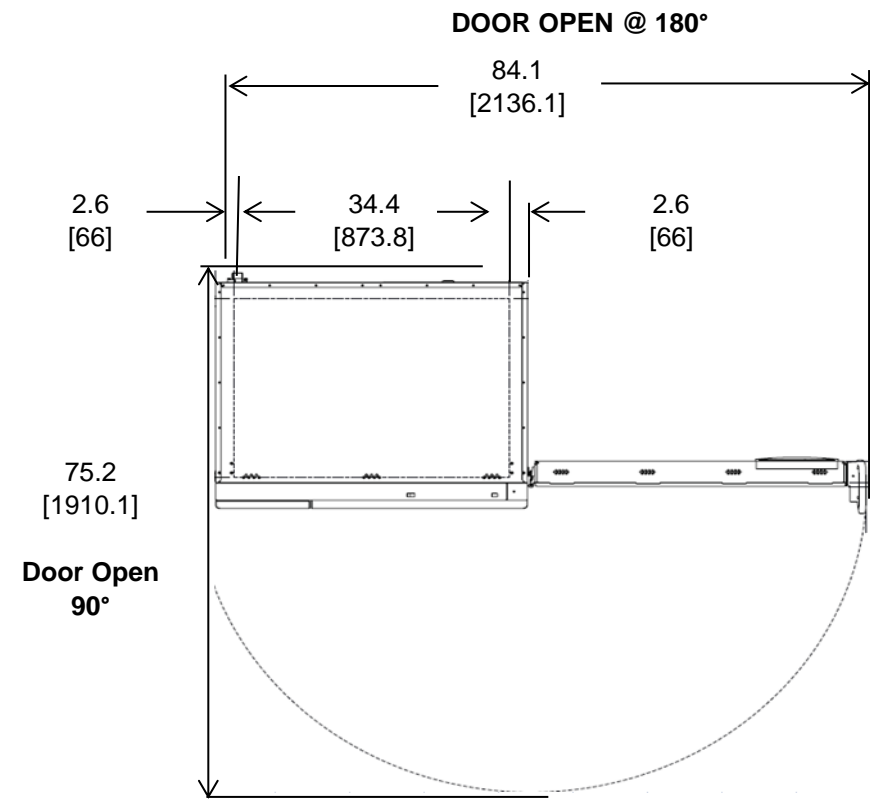

*Chart recorder/Back up systems are stand alone on 300 models.

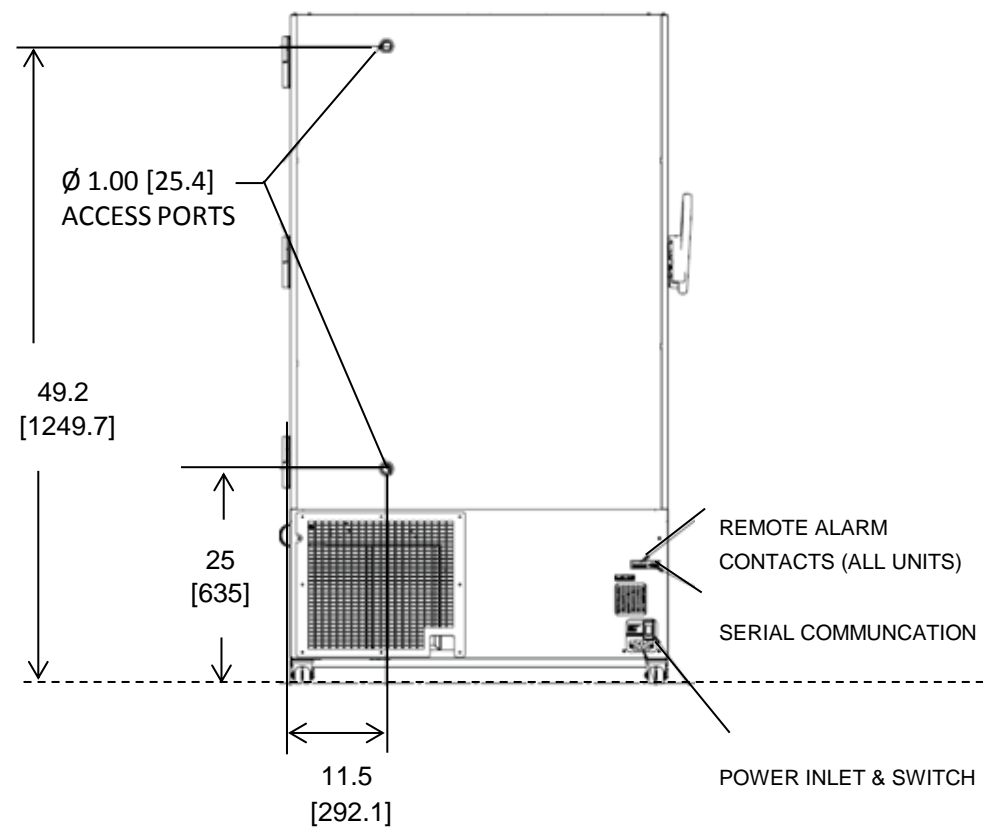

BACK

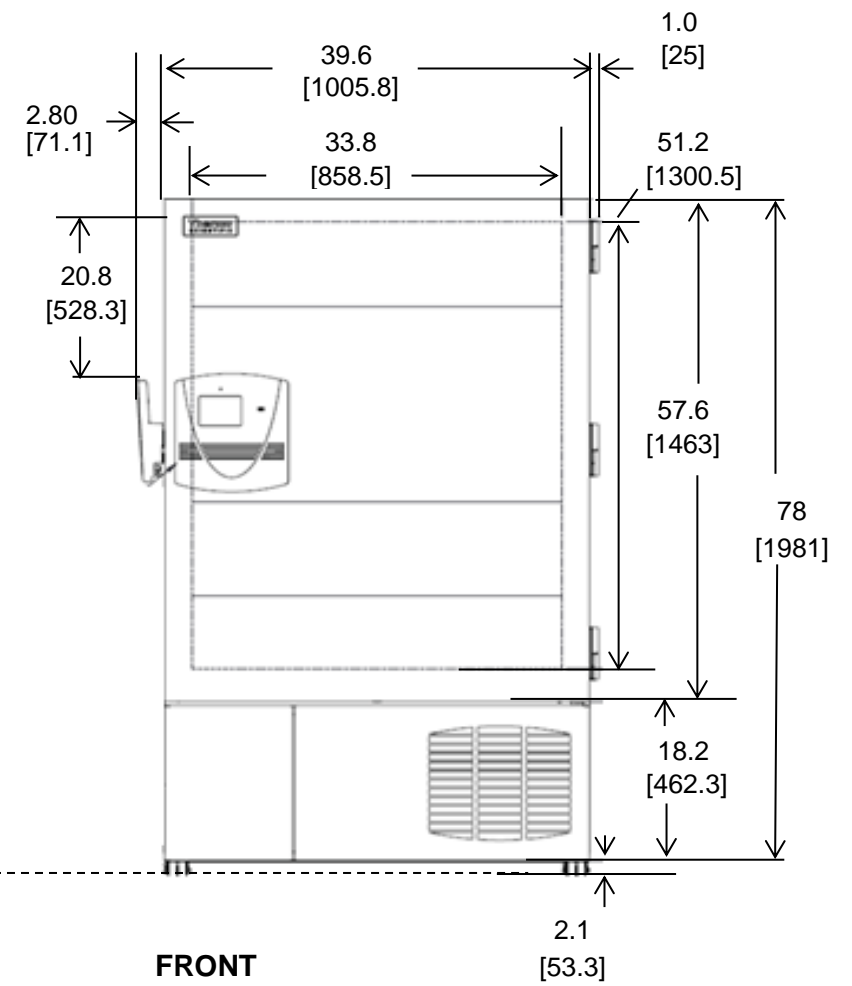
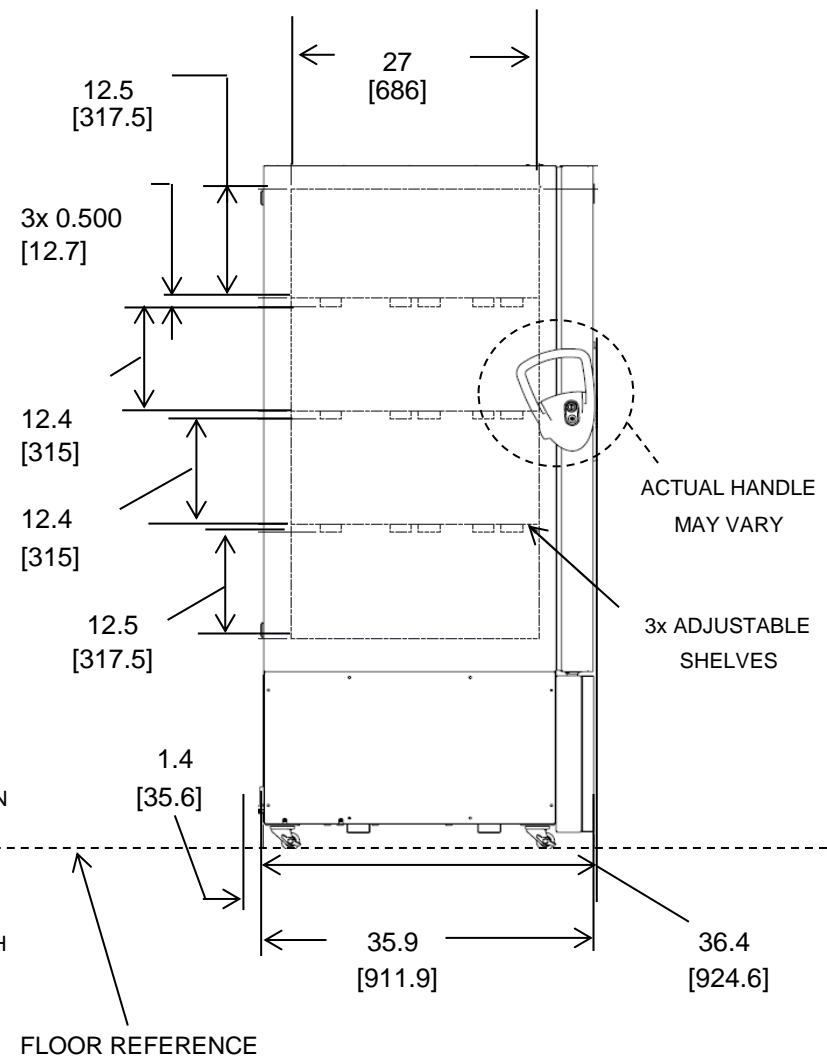

NOTE: DUAL DIMENSION IS INCH OVER METRIC

DO NOT USE FOR ENGINEERING PURPOSES. SUBJECT TO CHANGE WITHOUT NOTICE.

Thermo
SCIENTIFIC

29 cuft Upright Freezer
4 Inner Doors
Single Outer Door
Top Mount Controls