



Technical Data Sheet

Revco Ultra-Low Temperature Chest Freezer

MODEL RELEASE - 20

Thermo Fisher Scientific, Marietta, Ohio

Specifications	Model Number
	ULT390-10-V
Application, Rating and Electrical Data	
Application	Storage of General (non-flammable) Laboratory Materials
Storage Volume	84.9 Liters/3.0 Cubic Feet
Temperature Rating	-50°C to -86°C
Electrical Power	230V 50 Hz, 1 Phase
Instrument Rated Current	5.4 AMP
Building Supply Rating	15.0A (min) dedicated grounded circuit. Protected by circuit breaker rated for inductive loads
Power Plug/Power Cord Length	Country Dependant plug / IEC Cords, 3.048 Meters (10 Feet)
Agency Listings	CE, FDA
Indoor/Outdoor Usage	Indoor Use Only
Application Environment	Non-Corrosive, Non-Flammable, Non-Explosive, Good Air Ventilation, 18° C - 32° C (64.4° F - 89.6° F)
Refrigeration Configuration	
Refrigeration System	Industrial-Rated Two Stage Cascade System
Compressor / Number	Hermetic Compressor for Low Temperature Application / 2
Compressor Capacity*	730 W
Condenser Type/Number	Enhanced Finned-Tube and Forced-Air Cooled / 1
Expansion Device	Capillary Tube
Evaporator Type	Cold Wall With Enhanced Heat Transfer Treatment
Defrost Method	Manual Defrost
Refrigerant Charge/Flammability	R404A in 1st Stage / R508B+R290 Mix in 2nd Stage / Non-Flammable
Controller/Electrical System Configuration and Features	
Controller Level	Bottom
Power Switch	On-Off with Circuit Breaker
Controller Type	Microprocess Control
Setpoint Security	Yes
Compressor Safe Guard	High Pressure Cutout Switch/High Temp Cutout Switch/Current protection/Logic protection
Control Sensor	Single RTD (1000 ohm Platinum RTD)
Remote Alarm Terminals	RS485, 4-20mA, Dry Contacts
Adjustable Warm/Cold Alarms	Fully Adjustable
Auto-Voltage Safeguard	Buck/Boost System
Dimensions and Construction	
Interior Dimensions (H x D x W)	419 H x 470 D x 470 W mm (16.5 H x 18.5 D x 18.5 W in.)
Exterior Dimensions (H x D x W)	1110 H x 760 D x 724 W mm (43.7 H x 29.9 D x 28.5 W in.)
Shipping Dimensions	1252 H x 965 D x 953 W mm (49.3 H x 38 D x 37.5 W in.)
Insulation	High Density Polyurethane Foam, R-30 (ft ² ·°F·hr/Btu)
Door Seal	Silicone-Based High Performance Seal Gasket
Shelves / Capacity	N/A
All-Direction Casters	Standard with Locks
Unit Weight	Approximately 173 kg / 382 lbs.
Other Options	Electronic Recorder and CO ₂ or LN ₂ Back-Up System
Typical Performance Characteristics in 25 ° C Ambient	

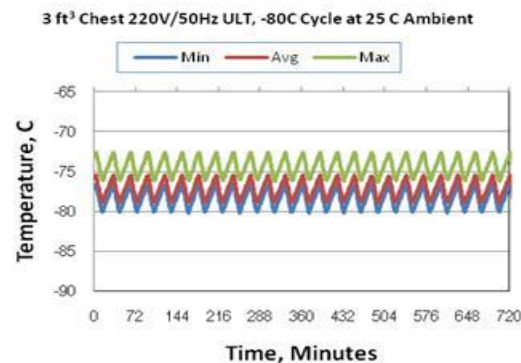
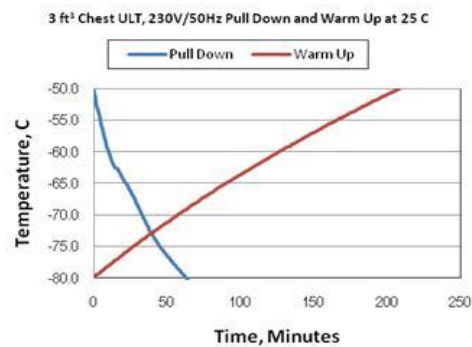

Test Unit Series Number or MSO Number:	18821-C-B
Cabinet Load:	Empty
Average Cabinet Temp at -80 C Cycle (C):	-77.2
Average Uniformity (C):	4.0
Average Stability (C):	3.5
Peak Variation (C):	7.6
Cycle (on/off) rate (minutes):	12 / 17
Duty Cycle (%):	41.8%
Avg. energy consumption (kW-hr/day):	5.3
Avg. heat rejection rate (Btu/hr):	760
Pulldown Time (-50 to -80 C) (minutes):	64
Warmup Time (-80 to -50 C) (minutes):	208

- Performance is nominal and individual units may vary.
- Freezer performance will differ due to product amount, product size and operating conditions.
- Continuous product enhancements may, without notice, result in amendments or omissions to this specification. Thermo Scientific cannot accept responsibility for damage, injury, loss or expenses resulting from misapplication of the information herein.

* Manufacturer measured compressor capacity taken at standard -23°C/49°C (Evap/Cond) condition.

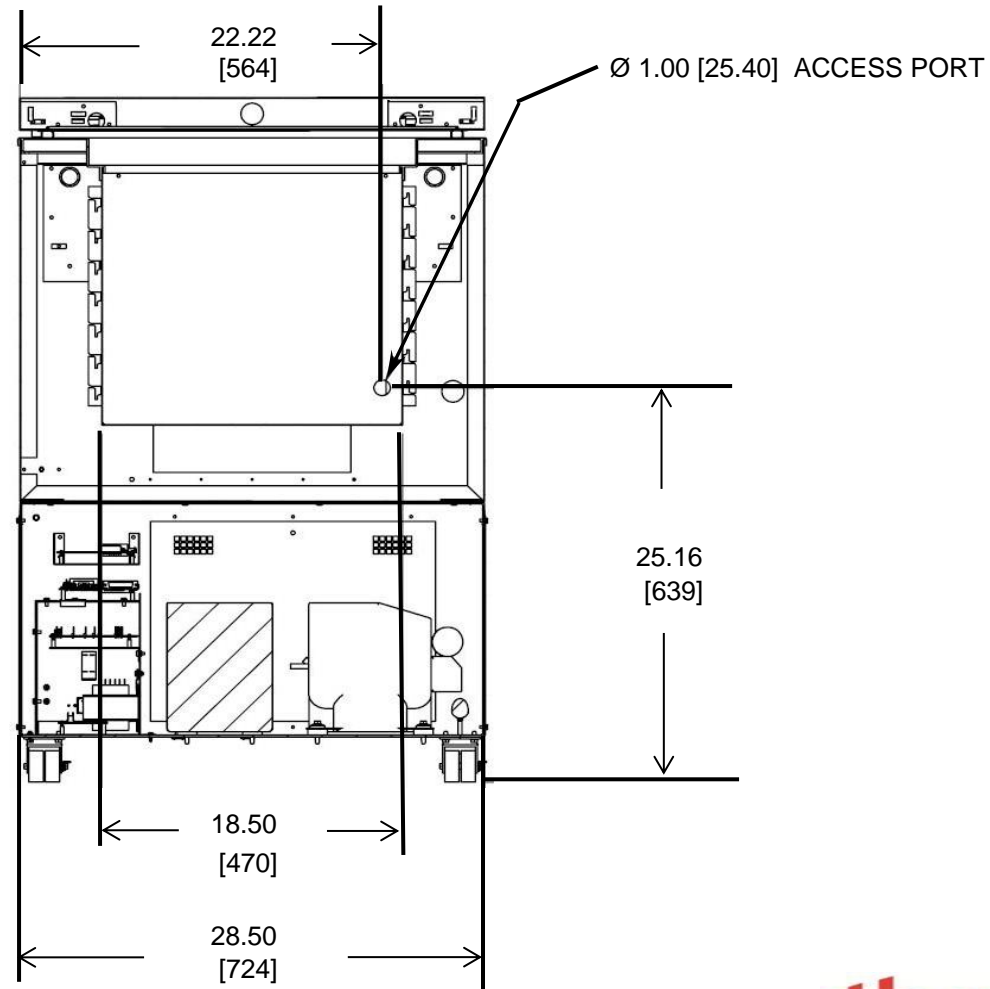
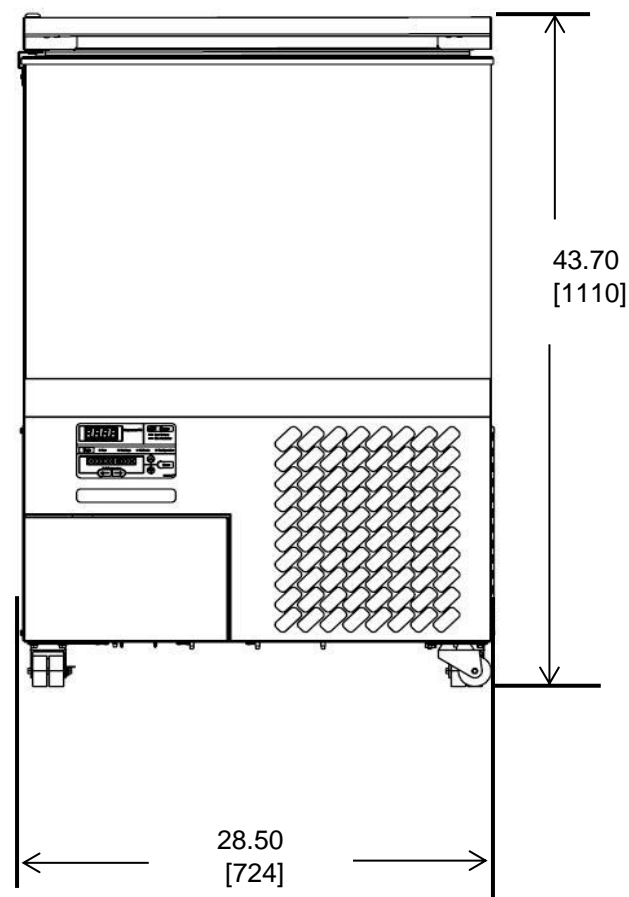
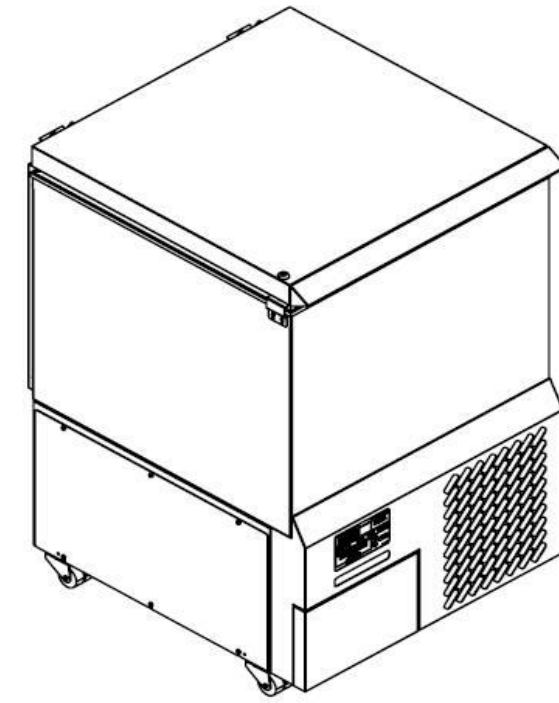
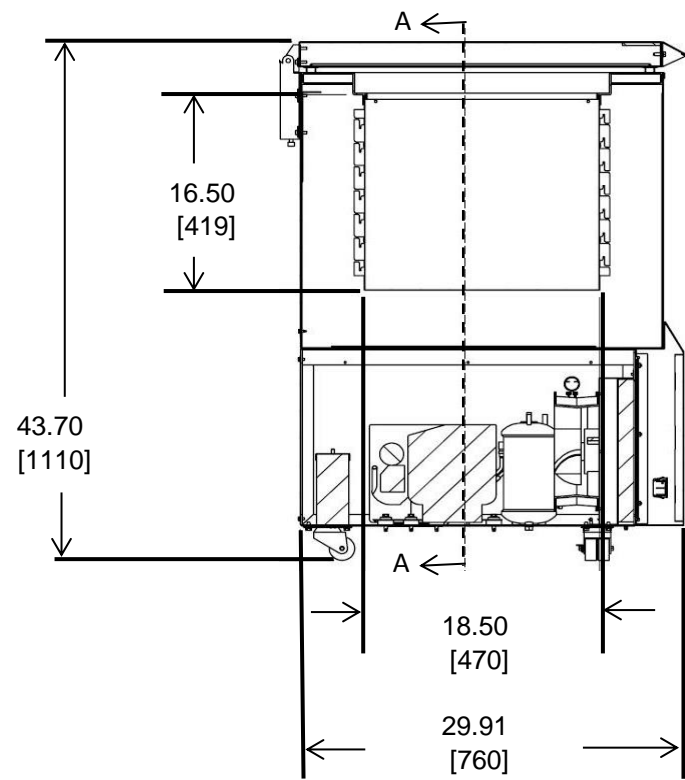

Section A-A

thermo
scientific

3 cuft Chest Freezer

NOTE: DUAL DIMENSION IS INCH OVER METRIC

DO NOT USE FOR ENGINEERING PURPOSES. SUBJECT TO CHANGE WITHOUT NOTICE.