

REVISIONS			
REV.	DESCRIPTION	DATE	CHANGED BY
A	UPDATED DRAWING	11/14/2014	M.A
B	UPDATED DRAWING	11/26/2014	M.A
C	UPDATED WITH PRETREATMENT	06/26/2015	M.A
D	UPDATED REAR PANEL WITH MOUNTING BRACKET & HOLES; UPDATED DRAWING PER STANDARDS; PRE TREATMENT 50157886 WAS 09.4000	03/20/2020	M.A

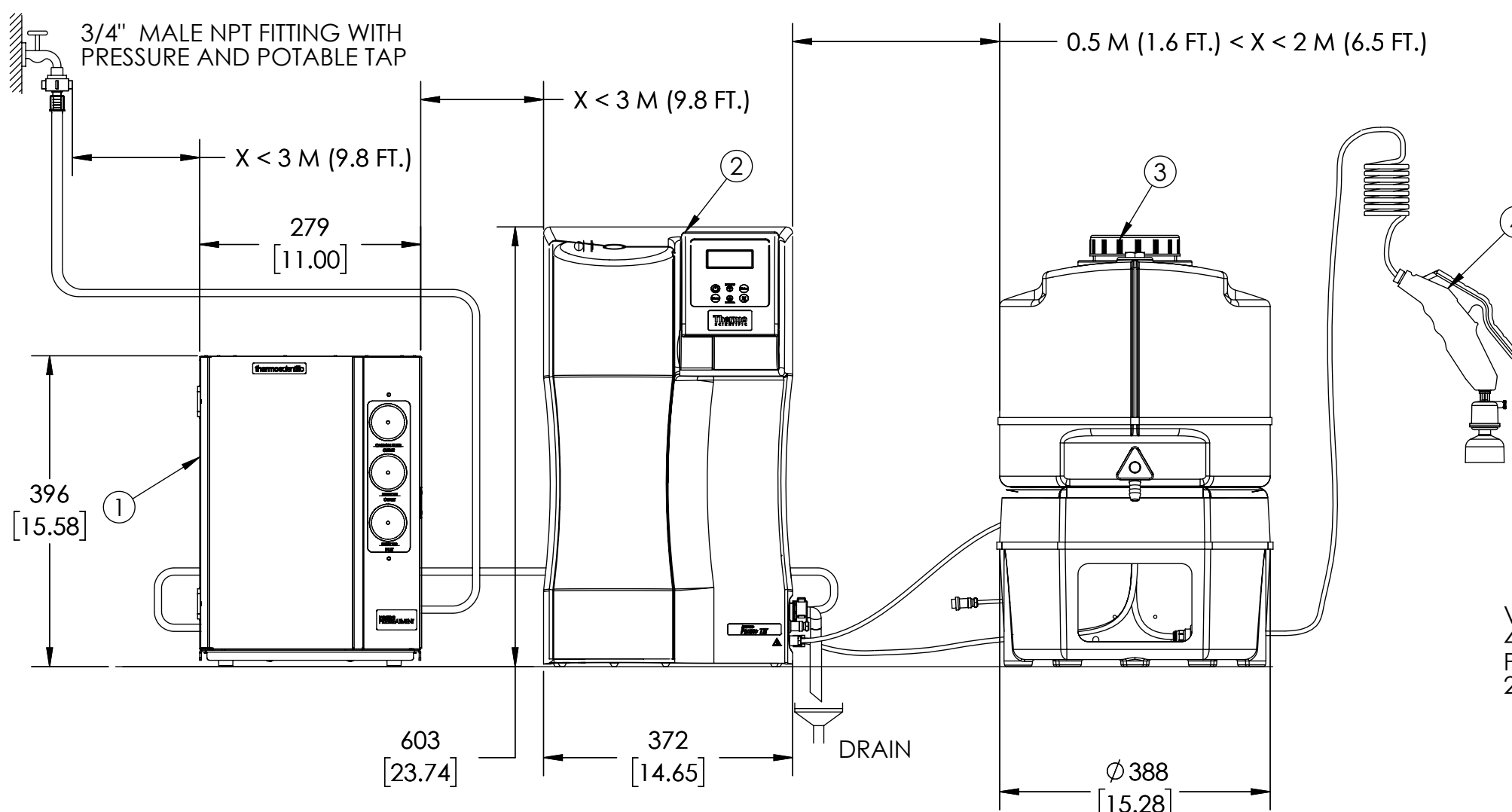

- LEGEND:
1. BARNSTEAD PRETREATMENT FOR BARNSTEAD PACIFIC TII/RO WATER SYSTEMS (ITEM NO. 50157886)
  2. BARNSTEAD PACIFIC TII/RO PURE WATER SYSTEM
  3. BARNSTEAD 30L RESERVOIR FOR PACIFIC TII/RO WATER SYSTEMS
  4. OPTIONAL HAND DISPENSER CAN BE UTILIZED UP TO 3M (108") FROM WATER SYSTEM
  5. HOLES FOR OPTIONAL WALL MOUNTING OF WATER SYSTEM WITH WALL MOUNTING BRACKET, 50157885
  6. OPTIONAL WALL MOUNTING BRACKET, 50157885
  7. OPTIONAL RESERVOIR WALL MOUNTING BRACKET (ITEM NO. 06.5015)

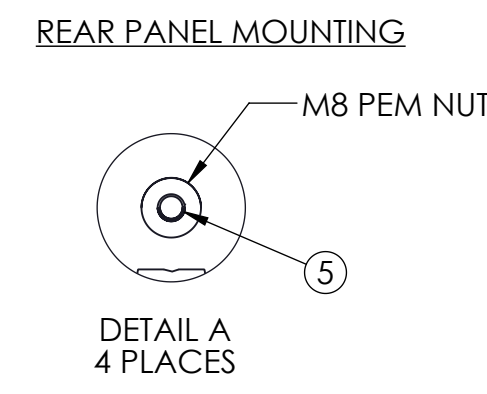
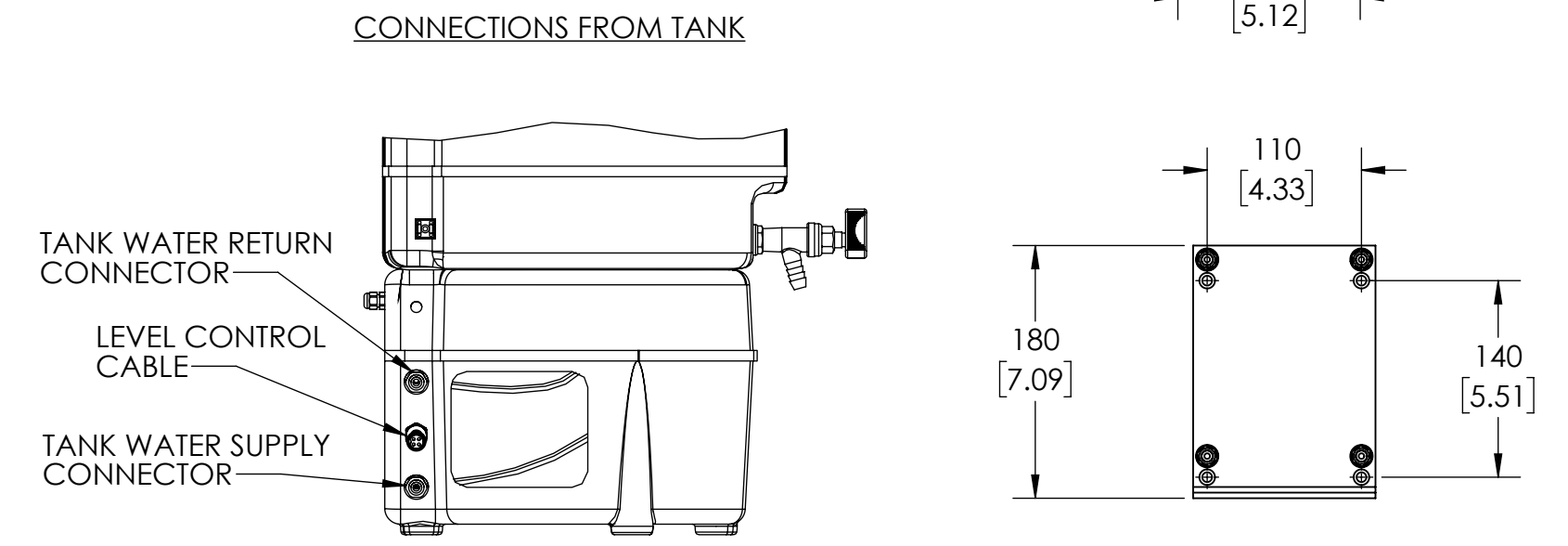
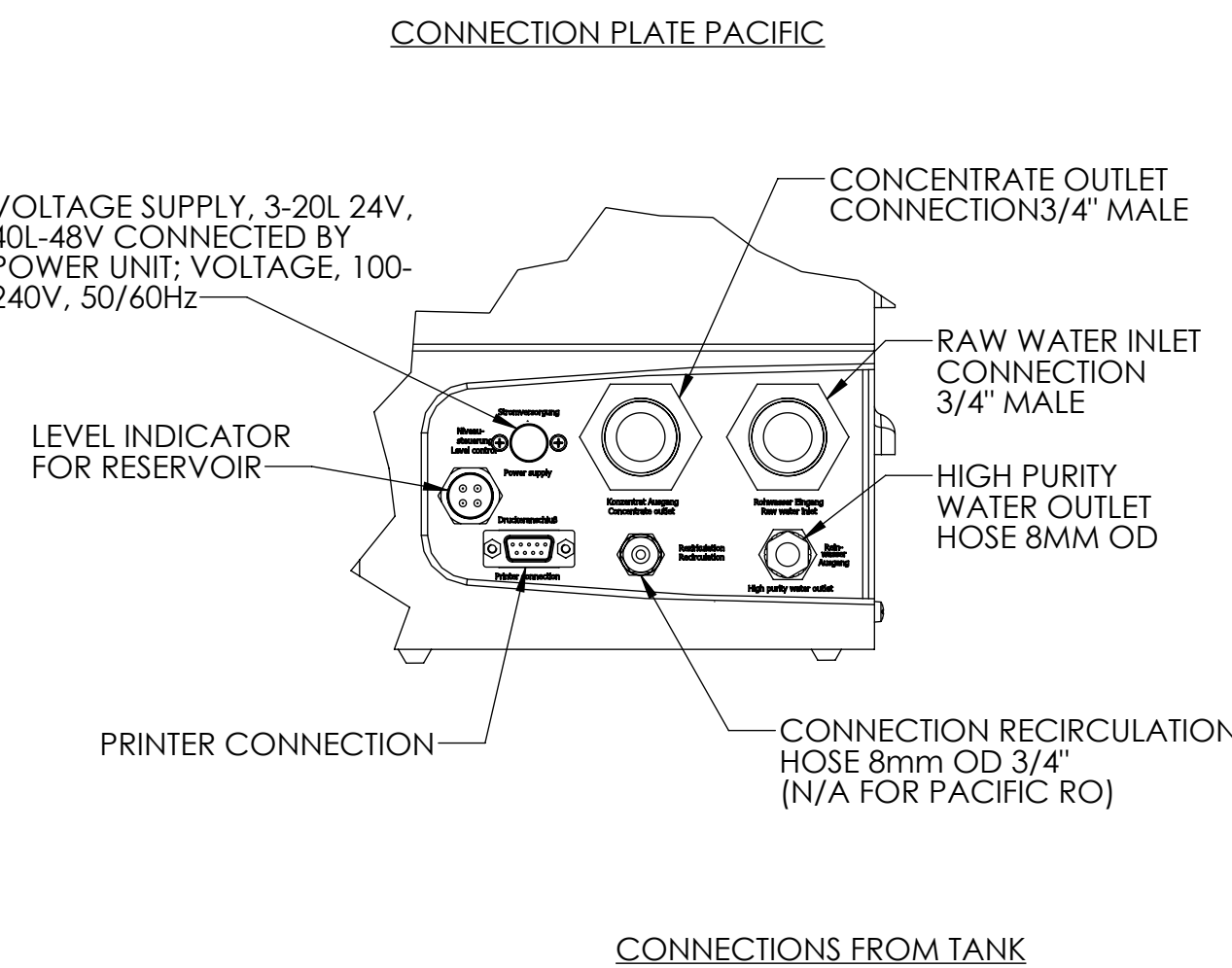
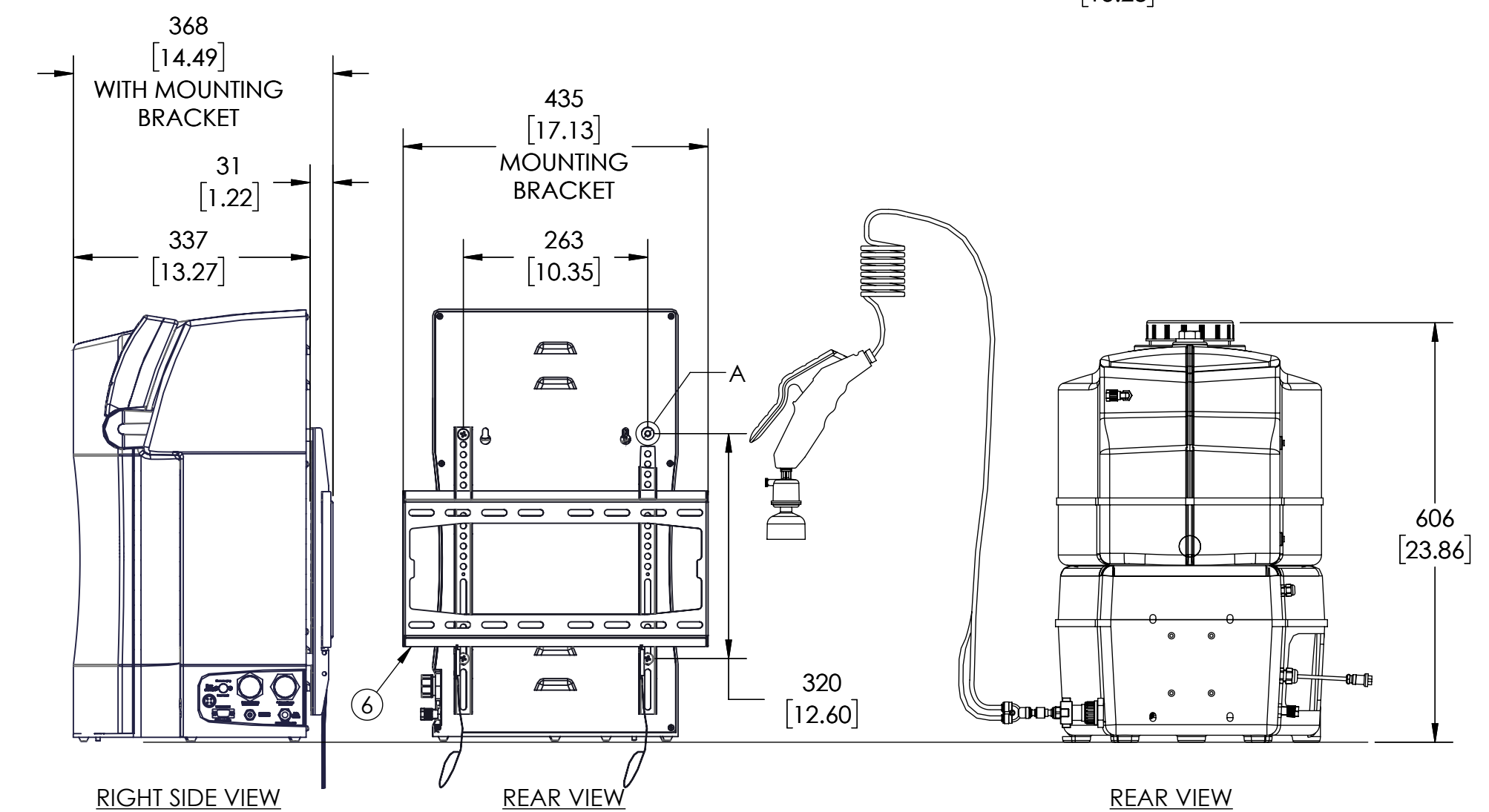

- NOTES:
1. DUAL DIMENSIONS ARE METRIC OVER INCH
  2. ENSURE THAT THERE IS ADEQUATE SPACE ALL AROUND THE UNIT APPROX. 30 CM (11.8 INCH) FOR CONSUMABLE REPLACEMENT

ELECTRICAL REQUIRMENTS	100-240 V, 50/60Hz, 2-1A, UPTO 1.5M(5 FEET) FROM UNIT
WATER CONNECTIONS	3/4" NPT WITH MANUAL SHUT OFF VALVE RECOMMENDED
MIN/MAX INLET PRESSURE	29-87 PSI (2-6 BAR)
RECOMMENDED FEED TEMPERATURE	2-40 °C
RECOMMENDED FEED WATER TYPE	TAP/POTABLE WATER
DRAIN	AN ATMOSPHERIC DRAIN MUST BE AVAILABLE WITHIN 1.5M(5 FEET) OF THE UNIT
UNIT WEIGHT	PACIFIC UNIT 23 KG (51 Lbs) DRY, 25 KG (55 Lbs) W/WATER 30L TANK 10 KG (22 Lbs) DRY, 40 KG (88 Lbs) W/WATER

CONFIDENTIAL INFORMATION

THIS DRAWING AND ALL INFORMATION AND FEATURES CONTAINED HEREIN ARE AND SHALL REMAIN THE EXCLUSIVE PROPERTY OF THERMO FISHER SCIENTIFIC. SHALL BE HELD CONFIDENTIAL, AND SHALL NOT BE REPRODUCED, COPIED, OR OTHERWISE DISPOSED OF, IN WHOLE OR IN PART, WITHOUT THE PRIOR WRITTEN PERMISSION OF THERMO FISHER SCIENTIFIC.

DO NOT SCALE DRAWING

DATE

DESIGNED BY AVADIEVA 10/07/2014

CHECKED BY OPP 10/07/2014

THIRD ANGLE PROJECTION

UNLESS OTHERWISE SPECIFIED, SURFACE ROUGHNESS SHALL BE:

SCALE: 1:1

DATE

TITLE

WALL MOUNTING BRACKET FOR TANK 30L PRETREATMENT, PACIFIC, 30L TANK

REV. 1

DWG. NO. MB118

SHEET 1 OF 1