

Thermo Scientific EZx Contaminant Detection System

The Thermo Scientific EZx contaminant detection system provides complete protection from metal, glass, stone, plastic and other dense foreign objects at a very affordable price. Especially attractive on lines utilizing new metallized film or foil packaging, the system is typically installed immediately after fill and seal. The system can screen your production 100% and immediately identify contaminants so you can take fast corrective action.



The Thermo Scientific EZx contaminant detection system provides the optimum solution for locating foreign objects commonly found in packaged food production environments. Utilizing an innovative and proprietary X-ray generation and processing approach, the system can find virtually any substance that is denser or sharper than the object it is contained in. This defect coverage is far superior to traditional magnetic metal detectors and can help overcome many of the traditional product effect challenges of those devices.

Designed with production line users in mind, the EZx™ contaminant detection system is very easy to learn and use. The built-in QuickLearn Wizard enables you to set up a new product in minutes. It automatically selects how to generate and process an image of your product.

And once running, the display shows an intuitive red light/green light status monitor along with simple summary statistics and reject images.

Unlike other X-ray systems, this platform was engineered to help you make the transition from metal detectors simple. It is available in five aperture sizes and various line heights; comes as a standalone system or with integrated rejecters; operates over a wide temperature range; meets IP65 washdown requirements; and adheres to even the strictest X-ray radiation standards. Although the EZx system is extremely reliable, in the event of a problem its modular design minimizes the time to repair. It can even be networked enabling simple and quick storage of all data for traceability.

Features and Benefits

- Designed to offer the lowest total cost of ownership of any X-ray system
- Unique source and detector design eliminates blind spots
- Certified for harsh environments, IP65 washdown
- Multiple size apertures available for optimum price/performance
- Intuitive on screen inspection results and run-time monitoring/adjustment
- QuickLearn Wizard gets you running in minutes
- Integrated rejecters, networking software and cooling options



**Standard EZx system with optional integrated rejecter
(air blast, lockable bin and reject verify/bin full photo eye shown)**



Unique X-Ray Design

The Thermo Scientific EZx is a conveyerized X-ray system designed to look and work more like a metal detector than a complex X-ray system. It utilizes a unique wrap around detector that assures there are never any “blind spots” in the inspection tunnel. The exceptionally reliable, wide beam X-ray source can easily penetrate most packaged foods without any trouble.

Intuitive Inspection Results

Summary inspection statistics are shown on screen and rejected product images can be reviewed when needed to determine corrective action. The run-time statistics data is logged by shift or batch for up to a month on the system. All statistics, images and log files can easily be transferred to a PC for archive and further analysis via a built-in USB port or optional Ethernet/FTP network connection.

Available Accessories/Options

- Integrated reject systems including several rejecter types, reject verify and bill full photo eyes and lockable reject bins. This option is now available for all EZx models.
- Networking and expanded product storage. Includes Ethernet/FTP hardware and software and additional memory. Networking setup and training included with installation.
- Air conditioning cooling (replaces the standard vortex cooler)
- Additional certified metal (ferrous, non-ferrous, stainless steel) and soda lime glass test cards. A basic kit of cards is included standard with every system.
- Spare parts kits and basic parts including spare belts and conveyor bearings
- Product alignment rails
- Special photoeye sensors for triggering and reject verification of low profile, light weight packages
- Country/region specific radiation testing and certification
- Radiation survey meter



Transfer data to any PC via the built-in USB port or optional network connection

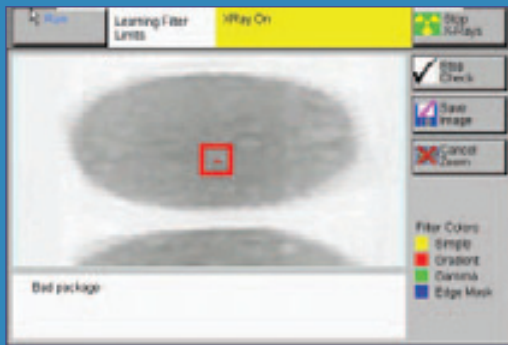

QuickLearn Wizard

Learning a new product is accomplished in minutes with the EZx touchscreen and a built-in wizard that makes all the tough decisions a snap. All you do is show the system several packages and it automatically determines what is “good.” Then you are prompted to test your setup by passing contaminants through the aperture—just like you would do during periodic audits when online. “Bad” packages are flagged and a zoomable image displays what the system found. Of course, all machine parameters can be set manually and new contaminant finding algorithms are available periodically as software upgrades.

Easily view run-time parameters and adjust them on-the-fly for optimum performance

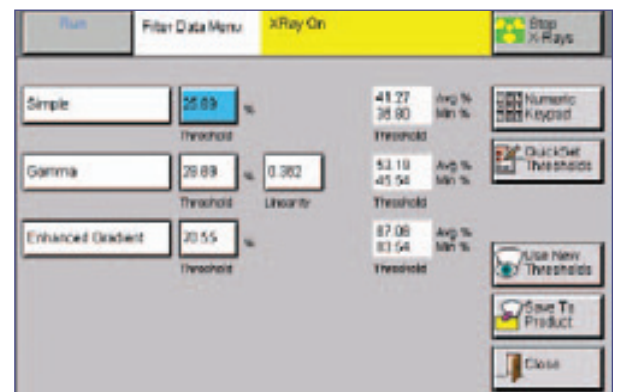

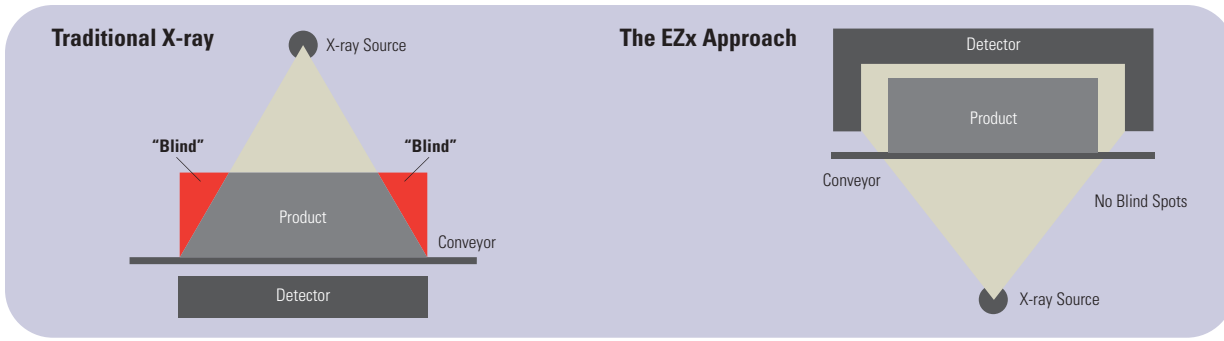

Innovative Machine Design

The EZx contaminant detection system was designed with food safety and sanitation principles in mind and has been tested to be IP65 compliant. All major components are modular for easy service from the front and the belt can be changed without tools. Five different conveyor heights are available and each is adjustable ± 50 mm (± 1.96 in) in the field. Several types of built-in reject mechanisms are available and general purpose I/O is included for external rejecters and custom applications. A photo sensor is included to trigger inspection and additional photo sensors are available to verify both product rejection and reject bin full. The system can operate in an environment up to $+40^{\circ}\text{C}$ ($+104^{\circ}\text{F}$) because of its built-in, extremely reliable vortex cooling. A cabinet air conditioning option is also offered for those installations where clean, dry compressed air is not readily available.

Optimized for Performance

Like traditional metal detectors, five aperture sizes are available (see Table 1 on back page) so you can optimize price and sensitivity to your package size. The X-ray source scans the aperture at a high rate resulting in typical inspection rates of 400 packages/minute or more. X-Ray detector calibration is automatically performed when loading and running a product and the detector is thermally stable so hot or frozen products do not affect performance. Finally, if inspection parameters need to be adjusted at run-time a password protected function is available to the technician. It displays the most recent conditions and enables changes on-the-fly with no impact to production.

Application Analysis and Aftermarket Services

Prior to purchasing an EZx contaminant detection system, our engineers will quickly and completely evaluate your application. A professional report is generated for review with your field salesperson. In addition, full machine specific characteristics are reviewed prior to order, assuring the system delivered meets your exacting requirements. After purchase, a wide range of services is available to support the system throughout its lifetime including full installation, training and radiation testing at the time of delivery. To ensure maximum operational efficiency, we offer on-site maintenance contracts and a full, spare-parts service. Finally, a Product Inspection Service (PIS) is available in many regions around the world to screen quarantined product, reducing costly scrap.

EZx Contaminant Detection System — Standard Model

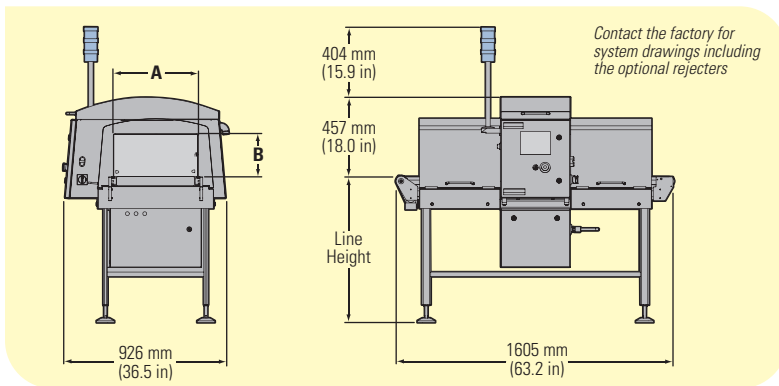

| EZx Model Number | Dimension A | Dimension B |
|------------------|-------------------|--------------------|
| Standard 210 | 197 mm (7.76 in) | 88.8 mm (3.50 in) |
| Standard 405 | 380 mm (14.96 in) | 37.4 mm (1.47 in) |
| Standard 410 | 380 mm (14.96 in) | 88.8 mm (3.50 in) |
| Standard 420 | 380 mm (14.96 in) | 193.0 mm (7.60 in) |
| Standard 510 | 483 mm (19.02 in) | 88.8 mm (3.50 in) |
| Standard 520 | 483 mm (19.02 in) | 193.0 mm (7.60 in) |

EZx Contaminant Detection System — Compact Model

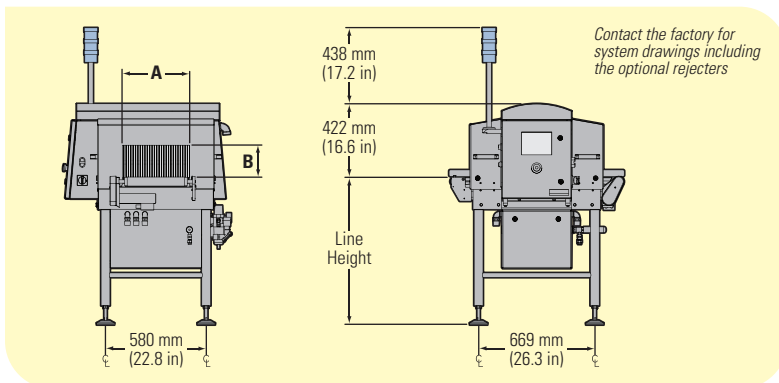

| EZx Model Number | Dimension A | Dimension B |
|------------------|-------------------|------------------|
| Compact 210 | 200 mm (7.87 in) | 100 mm (3.93 in) |
| Compact 410 | 400 mm (15.75 in) | 100 mm (3.93 in) |
| Compact 420 | 400 mm (15.75 in) | 200 mm (7.87 in) |

Thermo Scientific EZx

Application and X-ray Specifications

| | |
|--|--|
| X-ray Power | 160 Watts, 80 KV/2 ma maximum |
| Scan Rate | Up to 2000 lines per second |
| A/D Converter | 12 bit, 4096 gray scale images |
| Warm-up Time | Less than 30 minutes |
| Typical Sensitivity | 1-2 mm diameter for metal, >2 mm for other dense contaminants such as glass, stone and some types of plastic |
| Detection Filters Available | Simple threshold, gradient and enhanced (log contrast adjustment) gradient and Gamma correction |
| Other Image Processing Functions | Side and leading/trailing edge masking |
| Aperture/Product Width and Height | See specifics in Table 1 |
| Maximum Belt Speed | See specifics in Table 1, depends on aperture width |
| Conveyor Heights (specify at order time) | 750 mm (29.5 in), 850 mm (33.5 in), 950 mm (37.4 in), 1050 mm (41.3 in), 1150 mm (45.3 in); Field adjustable ±50 mm/±2 in |
| Conveyor Length | Standard: 1.6 m (5.25 ft); Compact: 1 m (39.37 in); does not include optional rejecters for models 410, 420, 510 and 520 |
| Belt Material | USDA/FDA approved urethane |
| Inspection Trigger Photo Sensor | Through beam or optional range sensor for flat packages; 35 mm (1.4 in) minimum product gap required |
| Security/Safety Features | X-ray power key, four level password system, emergency X-ray/conveyor stop button, lead curtains, failsafe X-ray eminent and on indication light |
| Human Machine Interface (HMI) | Microsoft® Windows® CE touchscreen, 203 mm (8 in) diagonal |
| Language Interfaces Available | English, Spanish, French, Italian, German, Chinese and Czechoslovakian |
| Inspection Data Available | Packs inspected, accepted and rejected by shift and batch; Rejects timestamped and assigned a reject code |
| Data File Export | Via built-in USB port or optional network connection; Files tab/space/return delimited text for import to Microsoft Excel® |
| Built-in Rejecter Option | Air blast or pusher, lockable reject bin and reject verify/bin full photo eyes |

Environmental, Electrical and Operational Specifications

| | |
|----------------------------|--|
| Operating Temperature | +15°C to +40°C (+60°F to +104°F) |
| Relative Humidity | 20% to 90% |
| Electrical Supply | 85 VAC to 250 VAC, 50/60 Hz, autosensing, single phase |
| Digital Outputs/Allocation | Eight outputs, form C (SPDT) relays, 250 VAC 2A provided, assignable function |
| Digital Inputs/Allocation | Eight inputs, contact closure, 6 NPN, 2 NPN/PNP, 10-30 VDC 10 mA, assignable function |
| USB Port | Watertight USB 1.1; memory stick included |
| Network Option | 10/100 Ethernet TCP/IP and FTP; RJ45 network connection |
| Compressed Air | Dry 80-100 PSI (5.5-6.9 bar), 40 CFM (1135 LPM), 25 micron air filter, 6.35 mm (0.25 in) tubing, NPT 0.25-in thread. |
| Machine Weight | 227 kg (500 lb) not including rejecters |

Conformance Tests and Certifications

| | |
|------------------------------|--|
| Radiation Safety Conformance | FDA CFR 21 part 1020.40; UK IRR 1999; France NFC 74100; Canada RED Act; Spain CSNE (contact factory for other regional certifications) |
| Export/Safety Certification | CE, cCSAus, CSA |
| IP Washdown Conformance | IP65, see factory for test results; Full stainless steel type 304 construction |
| Ambient Noise at HMI | <75 dB (Meets OSHA 29 CFR 1910.95) |
| Emissions and Immunity | EN61326-1: 1997 |
| Manufacturing Quality | ISO9001 certified facility |

Table 1: EZx Application Parameters

| EZx Model Number | Package Width | Package Height | Aperture Width | Aperture Height | Maximum Conveyor Speed |
|------------------|------------------|-----------------|------------------|-----------------|------------------------|
| 210 | 150 mm (5.90 in) | 85 mm (3.3 in) | 200 mm (7.90 in) | 100 mm (4.0 in) | 100 m/min (328 ft/min) |
| 405 | 340 mm (13.4 in) | 35 mm (1.4 in) | 400 mm (15.8 in) | 50 mm (2.0 in) | 100 m/min (328 ft/min) |
| 410 | 340 mm (13.4 in) | 85 mm (3.3 in) | 400 mm (15.8 in) | 100 mm (4.0 in) | 100 m/min (328 ft/min) |
| 420 | 340 mm (13.4 in) | 185 mm (7.3 in) | 400 mm (15.8 in) | 200 mm (7.9 in) | 50 m/min (164 ft/min) |
| 510 | 440 mm (17.3 in) | 85 mm (3.3 in) | 500 mm (19.7 in) | 100 mm (4.0 in) | 50 m/min (164 ft/min) |
| 520 | 440 mm (17.3 in) | 185 mm (7.3 in) | 500 mm (19.7 in) | 200 mm (7.9 in) | 50 m/min (164 ft/min) |

© 2010 Thermo Fisher Scientific Inc. All rights reserved. Microsoft, Windows and Excel are either registered trademarks or trademarks of Microsoft Corporation in the United States and/or other countries. All other trademarks are the property of Thermo Fisher Scientific Inc. and its subsidiaries. Results may vary under different operating conditions. Specifications, terms and pricing are subject to change. Not all products are available in all countries. Please consult your local sales representative for details. Literature Code PL.0037.1010

| | | | |
|--|---|--|--|
| Africa +27 (0) 11-609-3101 +27 (0) 11-609-3110 fax | India +91 (20) 6626 7000 +91 (20) 6626 7001 fax | Netherlands +31 (0) 76-579-5555 +39 0521 2729-14 fax | United Kingdom +44 (0) 1788-820300 +44 (0) 1788-820301 fax |
| Asia/Australia +86 (0) 21 6865 4588 +86 (0) 21 6445 1101 fax | Italy +39 0521 7886-1 +39 0521 2729-14 fax | Spain +34 (0) 91-484-5965 +39 0521 2729-14 fax | United States & Canada +1 (800) 227-8891 +1 (763) 783-2525 fax +1 (763) 783-2500 direct |
| France +33 (0) 160 92 48 00 +39 0521 2729-14 fax | Latin America +52 (01) 55 5638 0237 +52 (01) 55 5639 2227 fax | | |
| Germany +49 (0) 208-824930 +39 0521 2729-14 fax | Malaysia +60 (0) 3 5122 8888 +60 (0) 3 5121 8899 fax | | |

www.thermoscientific.com/productinspection